

ASPHERIC COEFFICIENTS

	R	k	A4	A6	A8	A10	A12
S1	1.586014	-2.062694	4.938263E-02	-6.116114E-03	1.717442E-03	-4.643557E-04	5.410885E-05
S2	PLANO	-	-	-	-	-	-

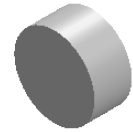

ASPHERIC LENS EQUATION

$$z = \frac{Y^2}{R(1 + \sqrt{1 - (1 + k)Y^2/R^2})} + A_4Y^4 + A_6Y^6 + A_8Y^8 + A_{10}Y^{10} + A_{12}Y^{12}$$

NOTES

- MATERIAL: D-ZLAF52LA
- DESIGN WAVELENGTH: 780.0 nm
- WORKING WAVELENGTH: 1100 nm-1700 nm
- CLEAR APERTURE: (S1) $\varnothing 2.00$ mm, (S2) $\varnothing 1.09$ mm
- NUMERICAL APERTURE: 0.5
- FOCAL LENGTH: 2.0 mm
- FOCAL LENGTH TOLERANCE: $\pm 1.0\%$
- BACK FOCAL LENGTH(REF): bf=1.0 mm
- DIAMETER TOLERANCE: ± 0.015 mm
- THICKNESS TOLERANCE: ± 0.03 mm
- CHAMFER: 0.2 mm, 45°
- SURFACE QUALITY: 40-20 SCRATCH-DIG
- WAVE FRONT ERROR: $< 0.07 \lambda$ RMS@632.8 nm
- CENTRATION: < 30 arcmin
- MAXIMUM TEMPERATURE: 250 °C(482 °F)
- AR COATING: $R_{avg} < 0.5\%$ @1100 nm-1700 nm, 0°AOI

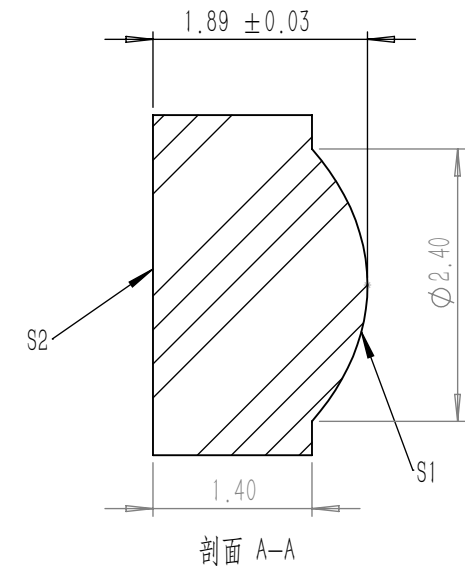
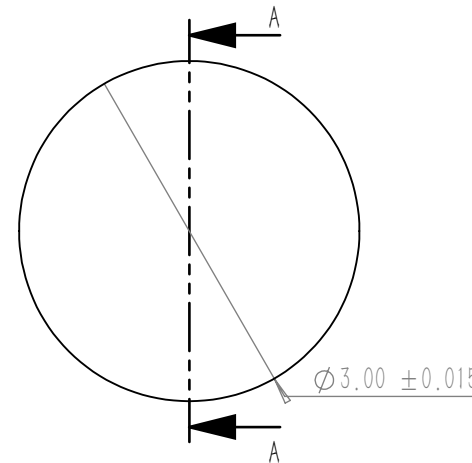

DRAWING PROJECTION			LBTEK			
	NAME	DATE	AC110314-C			
DRAWN	BSHU	Aug./1st/24	$\varnothing 3.0$ mm, F=2.0 mm ASPHERIC CONDENSER LENS AR COATING 1100-1700 nm			
APPROVAL	WCHENG	Aug./1st/24	MATERIAL	WEIGHT	SCALE	REV
FOR INFORMATION ONLY NOT FOR MANUFACTURING PURPOSES			D-ZLaF52LA	0.05g	15:1	A