

ASPHERIC COEFFICIENTS

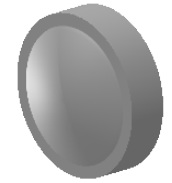

	R	k	A4	A6	A8	A10	A12
S1	3.879161	-0.431729	-8.168899E-03	-1.995690E-04	2.200933E-04	-3.982084E-05	2.656612E-06
S2	-3.879161	-0.431729	8.168899E-03	1.995690E-04	-2.200933E-04	3.982084E-05	2.656612E-06

ASPHERIC LENS EQUATION

$$z = \frac{Y^2}{R(1 + \sqrt{1 - (1 + k)Y^2/R^2})} + A_4Y^4 + A_6Y^6 + A_8Y^8 + A_{10}Y^{10} + A_{12}Y^{12}$$

NOTES

1. MATERIAL: D-ZLAF52LA
2. DESIGN WAVELENGTH: 830.0 nm
3. WORKING WAVELENGTH: 700 nm-1100 nm
4. CLEAR APERTURE: (S1) ϕ 3.60 mm, (S2) ϕ 3.60 mm
5. NUMERICAL APERTURE: 0.6
6. FOCAL LENGTH: 2.7 mm
7. FOCAL LENGTH TOLERANCE: $\pm 1.0\%$
8. BACK FOCAL LENGTH(REF): bf=2.1 mm
9. DIAMETER TOLERANCE: ± 0.015 mm
10. THICKNESS TOLERANCE: ± 0.04 mm
11. CHAMFER: 0.2 mm, 45°
12. SURFACE QUALITY: 40-20 SCRATCH-DIG
13. WAVE FRONT ERROR: 1.3-5.4 λ @632.8 nm
14. CENTRATION: < 30 arcmin
15. MAXIMUM TEMPERATURE: 250 °C(482 °F)
16. AR COATING: $R_{avg} < 0.5\%$ @700 nm-1100 nm, 0°AOI

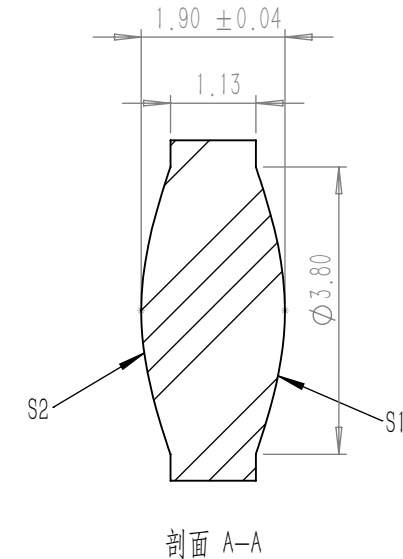
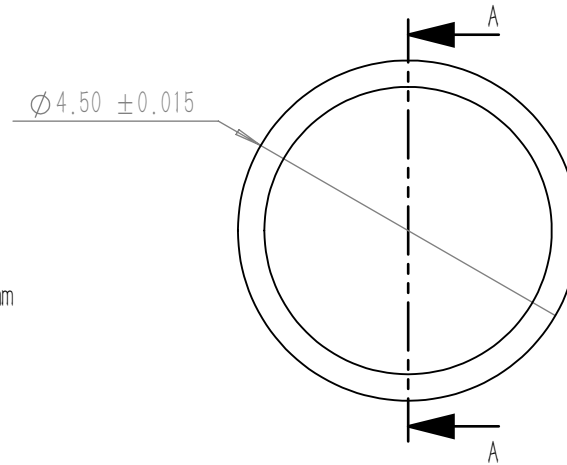

DRAWING PROJECTION			LBTEK			
		NAME	DATE	AC110416-B		
DRAWN	BSHU	Aug./1st/24	ϕ 4.5 mm, F=2.7 mm ASPHERIC CONDENSER LENS AR COATING 700-1100 nm			
APPROVAL	WCHENG	Aug./1st/24	MATERIAL	WEIGHT	SCALE	REV
FOR INFORMATION ONLY NOT FOR MANUFACTURING PURPOSES			D-ZLaF52LA	0.10g	10:1	A