

	R	k	A4	A6	A8	A10	A12	A14	A16
S1	15.54	-1.35	2.3618134e-05	-1.1303079e-08	-1.1113906e-11	-2.3981714e-14	3.035791e-17	1.3660815e-19	-1.8881587e-22
S2	INFINITE	-	-	-	-	-	-	-	-

$$z = \frac{Y^2}{R(1 + \sqrt{1 - (1 + k)Y^2/R^2})} + A_4Y^4 + A_6Y^6 + A_8Y^8 + A_{10}Y^{10} + A_{12}Y^{12} + A_{14}Y^{14} + A_{16}Y^{16}$$

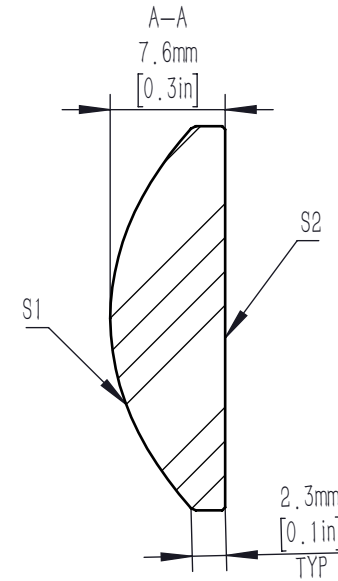
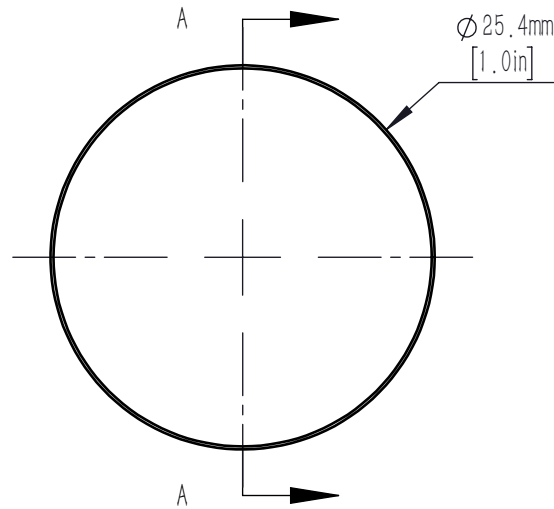
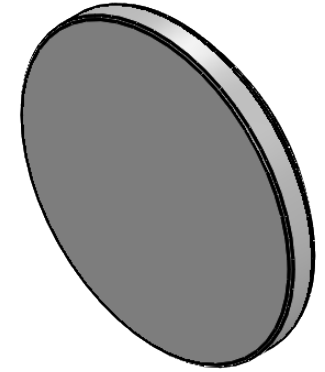

NOTES:

- MATERIAL: S-LAH64
- DESIGN WAVELENGTH: 780.0 nm
- NUMERICAL APERTURE: 0.50
- FOCAL LENGTH: 20.0 mm
- FOCAL LENGTH TOLERANCE:  $\pm 1\%$
- BACK FOCAL LENGTH(REF): BF=15.7 mm
- CLEAR APERTURE:  $>90\%$ CA
- DIAMETER TOLERANCE:  $+0.0/-0.1$  mm
- THICKNESS TOLERANCE:  $\pm 0.1$  mm
- CHAMFER: 0.2 mm,  $45^\circ$
- WAVEFRONT ERROR(RMS):  $<0.5 \mu\text{m}$
- SAG DEVIATION(POWER, S1):  $\pm 7.5 \mu\text{m}$
- SURFACE IRREGULARITY(S1):  $<3$  FRINGES
- SURFACE FLATNESS(S2):  $\lambda/4$
- SURFACE QUALITY: 60-40 SCRATCH-DIG
- CENTRATION:  $<3$  arcmin
- DAMAGE THRESHOLD: 9 J/cm<sup>2</sup>@810 nm, 10 ns, 10 HZ,  $\phi 0.155$  mm
- AR COATING(S1, S2): Ravg $<0.5\%$ @700-1100 nm, 6 °AOI

DRAWING PROJECTION			<b>LBTEK</b>			
NAME	DATE	AC7606-B				
DRAWN	SHAN	APR./18th/24	ASPHERIC LENS			
APPROVAL	WCHENG	APR./18th/24	MATERIAL	WEIGHT	SCALE	REV
FOR INFORMATION ONLY NOT FOR MANUFACTURING PURPOSES			S-LAH64	6.06g	2:1	B