

	R	k	A4	A6	A8	A10	A12	A14	A16
S1	31.075	-0.744	4.3665221e-07	-2.2713591e-10	-1.7042174e-13	-3.6809344e-17	8.9443459e-21	1.8501188e-23	-6.2704333e-27
S2	INFINITE	-	-	-	-	-	-	-	-

$$Z = \frac{Y^2}{R(1 + \sqrt{1 - (1 + K)Y^2/R^2})} + A_4Y^4 + A_6Y^6 + A_8Y^8 + A_{10}Y^{10} + A_{12}Y^{12} + A_{14}Y^{14} + A_{16}Y^{16}$$

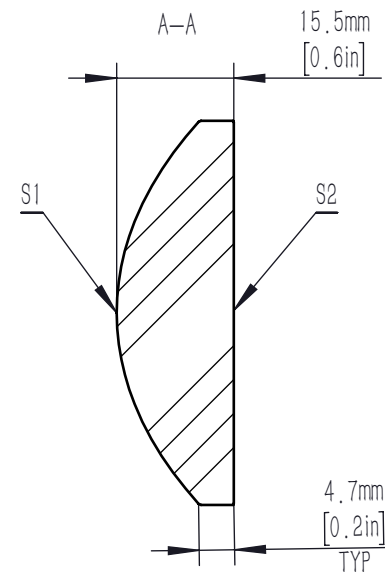
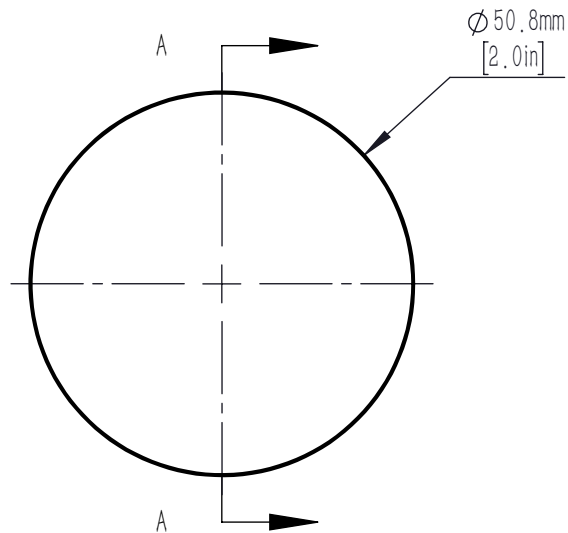
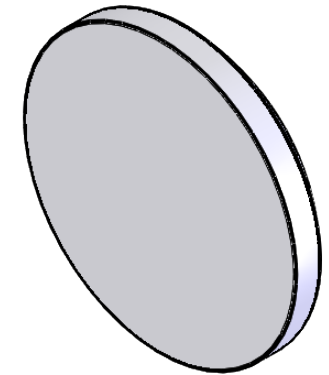

NOTES:

1. MATERIAL: S-LAH64
2. DESIGN WAVELENGTH: 780.0 nm
3. NUMERICAL APERTURE: 0.50
4. FOCAL LENGTH: 40.0 mm
5. FOCAL LENGTH TOLERANCE: $\pm 1\%$
6. BACK FOCAL LENGTH(REF): BF=31.3 mm
7. CLEAR APERTURE: $>90\%$ CA
8. DIAMETER TOLERANCE: $+0.0/-0.1$ mm
9. THICKNESS TOLERANCE: ± 0.1 mm
10. CHAMFER: 0.2 mm, 45°
11. WAVEFRONT ERROR(RMS): $<0.5 \mu\text{m}$
12. SAG DEVIATION(POWER, S1): $\pm 7.5 \mu\text{m}$
13. SURFACE IRREGULARITY(S1): <3 FRINGES
14. SURFACE FLATNESS(S2) : $\lambda/4$
15. SURFACE QUALITY: 60-40 SCRATCH-DIG
16. CENTRATION: <3 arcmin
17. DAMAGE THRESHOLD: 6 J/cm²@532 nm, 10 ns, 10 HZ, $\phi 0.345$ mm
18. AR COATING (S1, S2): Ravg $<0.5\%$ @700-1100 nm, 6 °AOI

DRAWING PROJECTION			LBTEK			
NAME	DATE	AC7807-B				
DRAWN	SHAN	APR./19th/24	ASPHERIC LENS			
APPROVAL	WCHENG	APR./19th/24	MATERIAL	WEIGHT	SCALE	REV
FOR INFORMATION ONLY NOT FOR MANUFACTURING PURPOSES			S-LAH64	50.0g	1:1	B