

ASPHERIC COEFFICIENTS

	R	k	A4
S1	8.090100	-0.679000	2.395000E-05
S2	PLANO	-	-

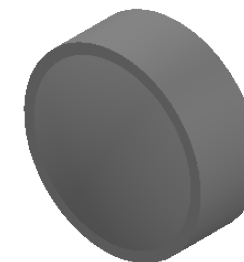

ASPHERIC LENS EQUATION

$$z = \frac{Y^2}{R(1 + \sqrt{1 - (1 + k)Y^2/R^2})} + A_4Y^4$$

NOTES

1. MATERIAL: D-ZK3
2. DESIGN WAVELENGTH: 650 nm
3. WORKING WAVELENGTH: 400 nm-700 nm
4. CLEAR APERTURE: (S1) ϕ 5.10 mm, (S2) ϕ 4.54 mm
5. NUMERICAL APERTURE: 0.2
6. FOCAL LENGTH: 13.8 mm
7. FOCAL LENGTH TOLERANCE: $\pm 1.0\%$
8. BACK FOCAL LENGTH(REF): bf=12.0 mm
9. DIAMETER TOLERANCE: ± 0.015 mm
10. THICKNESS TOLERANCE: ± 0.05 mm
11. CHAMFER: 0.2 mm, 45°
12. SURFACE QUALITY: 40-20 SCRATCH-DIG
13. WAVE FRONT ERROR: $< 0.07 \lambda$ RMS@632.8 nm
14. CENTRATION: < 30 arcmin
15. MAXIMUM TEMPERATURE: 250 °C(482 °F)
16. AR COATING: $R_{avg} < 0.5\%$ @400 nm-700 nm, 0°AOI

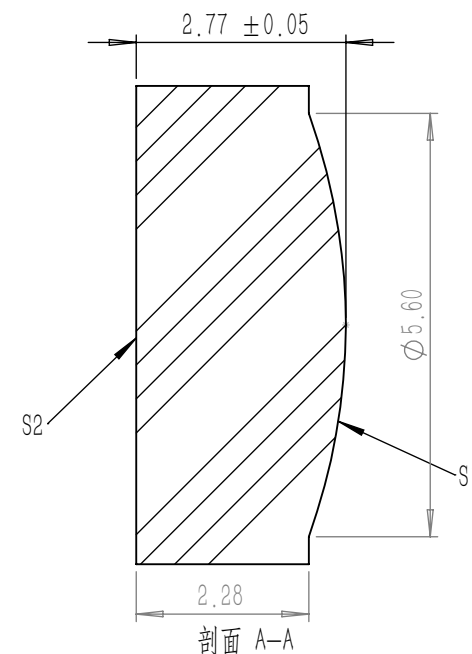
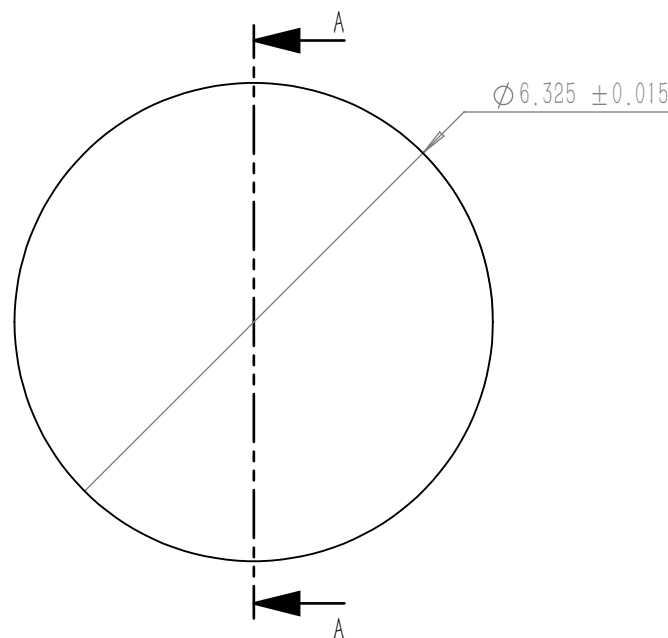

DRAWING PROJECTION			LBTEK			
	NAME	DATE	AC90620-A			
DRAWN	BSHU	Aug./1st/24	ϕ 6.3 mm, F=13.8 mm ASPHERIC CONDENSER LENS AR COATING 400-700 nm			
APPROVAL	WCHENG	Aug./1st/24	MATERIAL	WEIGHT	SCALE	REV
FOR INFORMATION ONLY NOT FOR MANUFACTURING PURPOSES			D-ZK3	0.22 g	10:1	A