

clamp screws for locking optics position (2x120°)

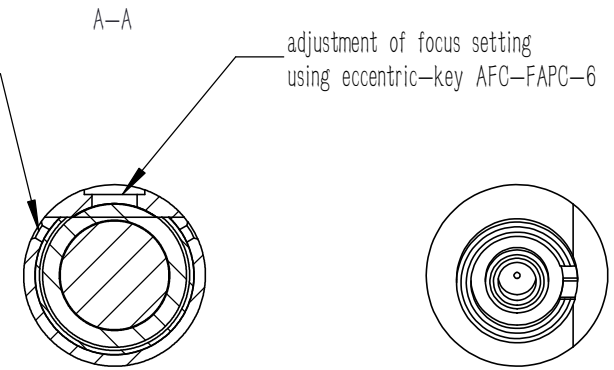

Pin screw for additional locking of the fiber ferrule:
 - before pulling the FC-APC-connector;
 unlock the pin screw.
 -before inserting the FC-APC-connector;
 make sure the ferrule is not blocked

clamp screws for locking of lens attachments (3x120°)

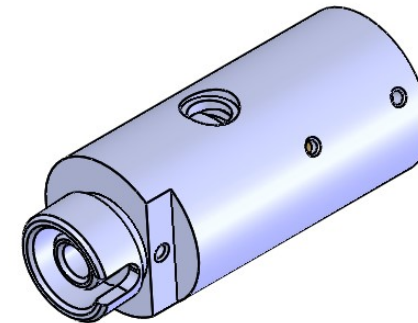
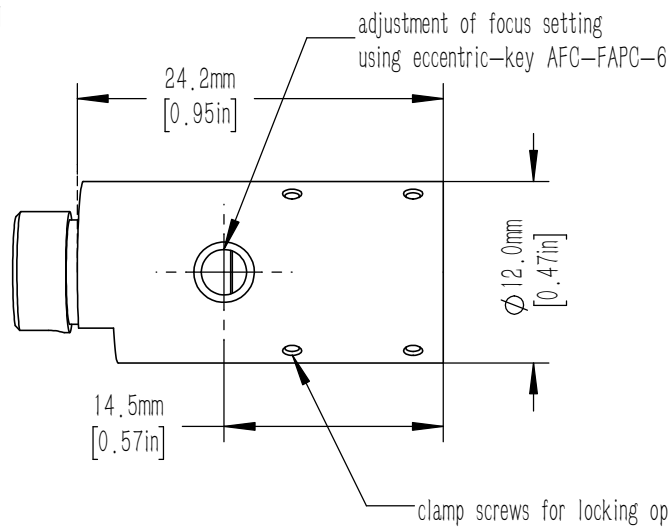

notes:

1. focal length: 11.0 mm
2. Waist beam spot diameter: 2.03 mm@460HP
3. NA: 0.3
4. Lens material: D-ZK3
5. Interface type: FC/APC
6. Lens coating: 350 - 700 nm

DRAWING PROJECTION			LBTEK			
	NAME	DATE	ADFCA-11.0-APC			
DRAWN	BSHU	Jan./6th/24	FIBER COLLIMATOR			
APPROVAL	WCHENG	Jan./6th/24	MATERIAL	WEIGHT	SCALE	REV
FOR INFORMATION ONLY NOT FOR MANUFACTURING PURPOSES			N/A	0.004 Kg	2:1	A