

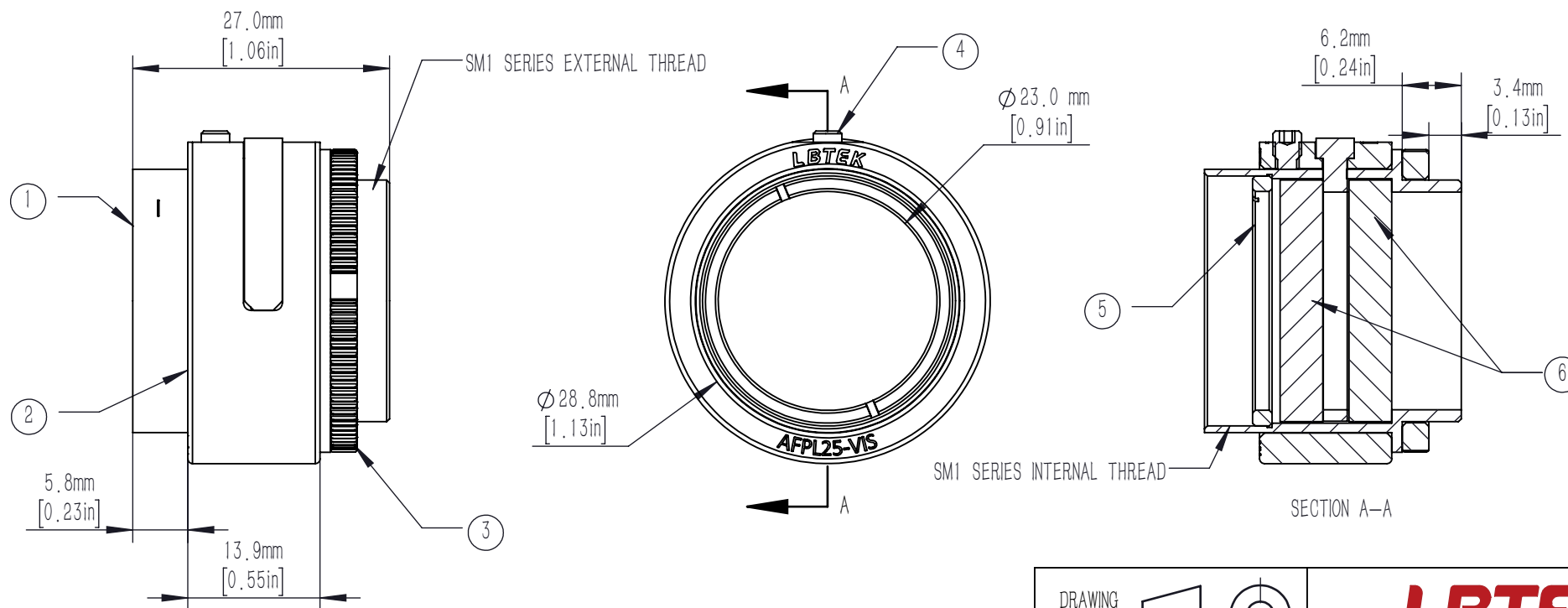

NUMBER	PART DESCRIPTION	MATERIAL
①	INNER HOUSING	BLACK ANODIZED ALUMINUM
②	KNURLED OUTER RING	BLACK ANODIZED ALUMINUM
③	SM1LR LOCKING RING	BLACK ANODIZED ALUMINUM
④	M3 × 2.5 LOCKING SCREW	STAINLESS STEEL
⑤	SM1R	BLACK ANODIZED ALUMINUM
⑥	FLP25-VIS-M POLARIZER	POLARIZED FILM/N-BK7



NOTES

1. WORKING WAVELENGTH: 400–700 nm
2. CLEAR APERTURE:  $\varnothing 21.5$  mm
3. EXTINCTION RATIO:  $>500:1@400-450$  nm  
 $>5000:1@450-700$  nm
4. SURFACE QUALITY: 40/20(S/D)

DRAWING PROJECTION			<b>LBTEK</b>			
NAME	DATE	AFPL25-VIS				
DRAWN	LZHOU	Aug./26th/24	VARIABLE FILM LINEAR POLARIZER ATTENUATOR @400–700 nm			
APPROVAL	WCHENG	Aug./26th/24	MATERIAL	WEIGHT	SCALE	REV
FOR INFORMATION ONLY NOT FOR MANUFACTURING PURPOSES			N/A	N/A	3:2	A