

剖面 A-A

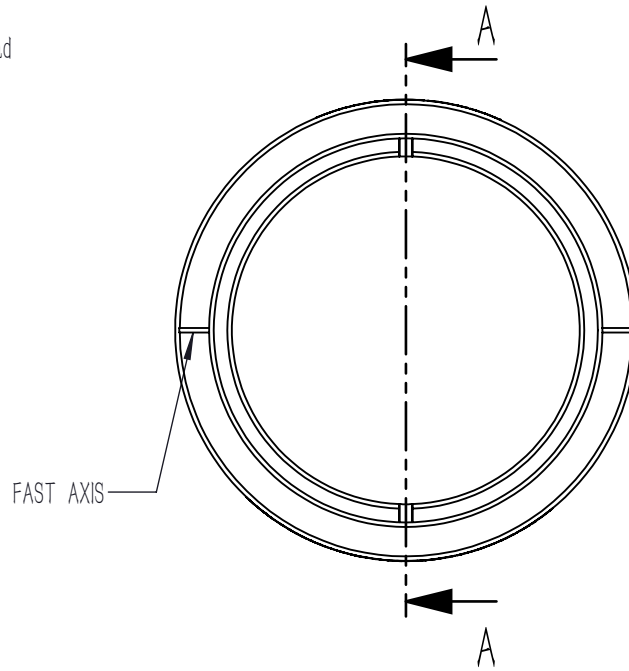

NOTES:

1. COMPONENT MATERIAL: LCP/N-BK7
2. COMPONENT SIZE: $\varnothing 25.4 \pm 0/-0.1$ mm
3. COMPONENT THICKNESS: 3.0 ± 0.1 mm
4. EDGE WIDTH: 0.7 ± 0.1 mm
5. WORKING WAVELENGTH: 700-1100 nm
6. RETARDANCE: $\lambda/2$
7. RETARDANCE UNIFORMITY: ± 5 nm
8. RETARDANCE PRECISION: $\pm \lambda/30@700-750$ nm
 $\pm \lambda/50@750-850$ nm
 $\pm \lambda/100@850-1100$ nm
9. SURFACE FINISHMENT (S/D) : 60/40
10. AR COATING (S1, S2) : $R_{avg} < 0.5\% @ 700-1100$ nm
11. MECHANICAL HOUSING SPECIFICATIONS: SMI-8A-SP



DRAWING PROJECTION			LBTEK			
	NAME	DATE	AHWP25-SNIR-A-M			
DRAWN	SHAN	JAN./15th/24	Achromatic Half-Wave Plate			
APPROVAL	WCHENG	JAN./15th/24	MATERIAL	WEIGHT	SCALE	REV
FOR INFORMATION ONLY NOT FOR MANUFACTURING PURPOSES			LCP/N-BK7	9.4 g	2:1	C