

剖面 A-A

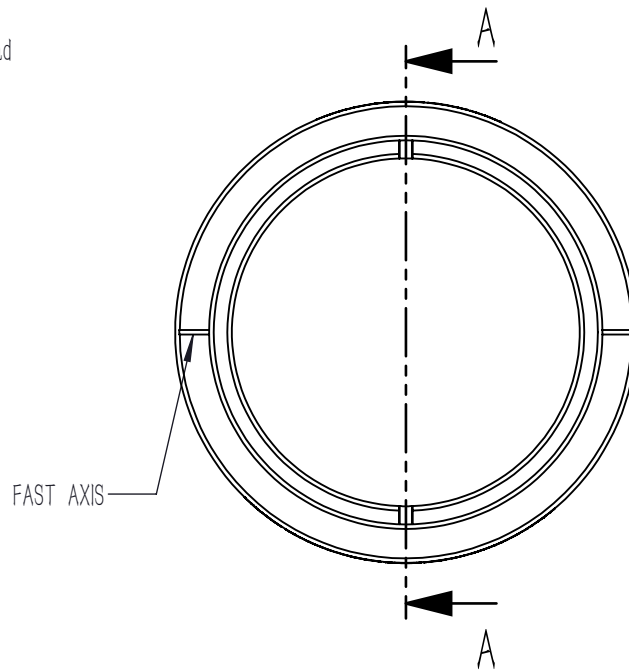

NOTES:

1. COMPONENT MATERIAL: LCP/N-BK7
2. COMPONENT SIZE:  $\varnothing 25.4 +0/-0.1$  mm
3. COMPONENT THICKNESS:  $3.0 \pm 0.1$  mm
4. EDGE WIDTH:  $0.7 \pm 0.1$  mm
5. WORKING WAVELENGTH: 600-800 nm
6. RETARDANCE:  $\lambda/2$
7. RETARDANCE UNIFORMITY:  $\pm 5$  nm
8. RETARDANCE PRECISION:  $\pm \lambda/30@600-650$  nm  
 $\pm \lambda/50@650-800$  nm
9. SURFACE FINISHMENT (S/D): 60/40
10. AR COATING (S1, S2):  $R_{avg} < 0.5\% @ 400-1100$  nm
11. MECHANICAL HOUSING SPECIFICATIONS: SMI-8A-SP



DRAWING PROJECTION			<b>LBTEK</b>			
	NAME	DATE				
DRAWN	SHAN	JAN./15th/24	Achromatic Half-Wave Plate			
APPROVAL	WCHENG	JAN./15th/24	MATERIAL	WEIGHT	SCALE	REV
FOR INFORMATION ONLY NOT FOR MANUFACTURING PURPOSES			LCP/N-BK7	9.4 g	2:1	C