

M5X0.25 LOCKABLE ADJUSTER SCREWS
 PROVIDES +/- 1mm TOTAL X/Y DISPLACEMENT
 (0.25mm PER REVOLUTION)
 2 PLACES
 2.0mm [5/64in] HEX

ADJUSTER LOCKING SCREW
 1.5mm[4/64in] HEX
 5 PLACES
 ADJUSTER LOCKING SCREW
 2.0mm[5/64in] HEX 3 PLACES

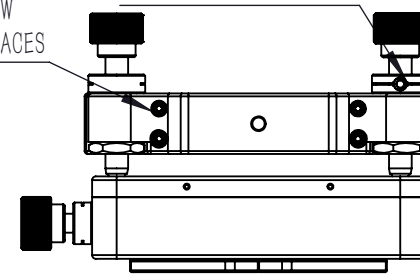

6X0.25 LOCKABLE ADJUSTER SCREWS
 PROVIDES +/- 4° TOTAL ANGULAR DISPLACEMENT
 (0.32° PER REVOLUTION)
 3 PLACES
 2.0mm [5/64in] HEX

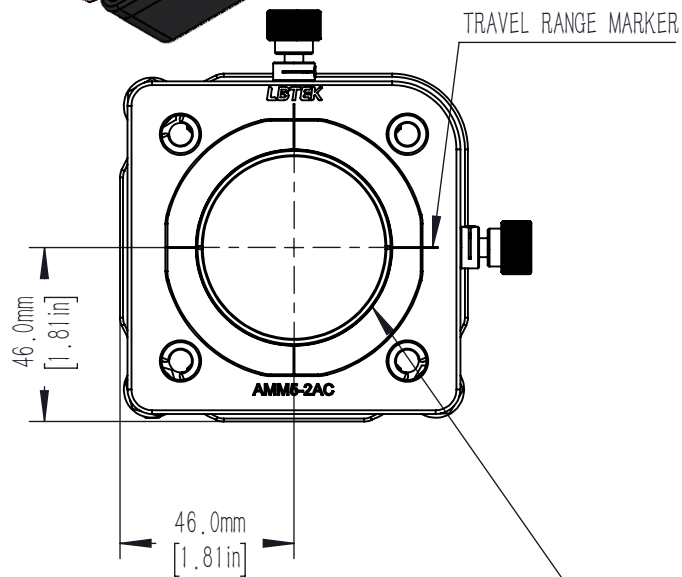

SM2 (2.035in-40) SERIES INTERNAL THREAD
 ACCEPTS ϕ 50.8mm [2.00in] MAXIMUM 16.0mm[0.63in] THICK OPTICS
 SM2R RETAINING RINGS INCLUDED
 ϕ 48.4mm [1.90in] CLEAR APERTURE

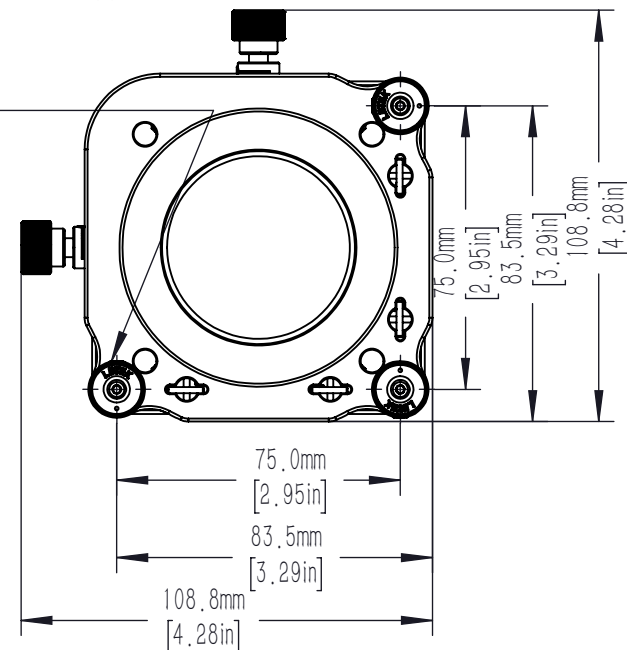
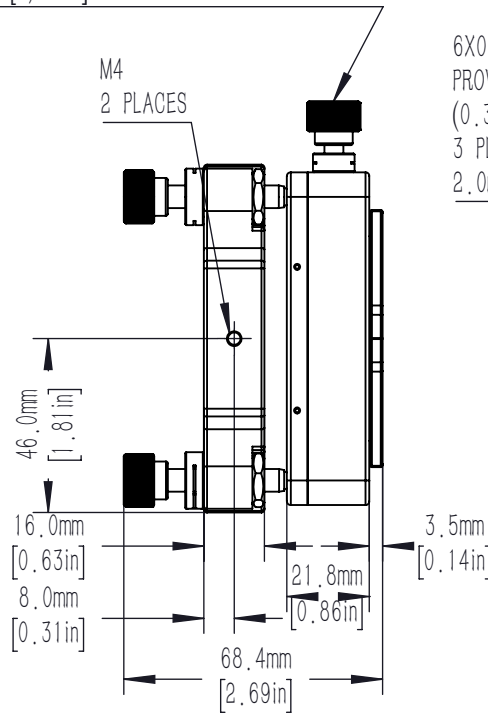

DRAWING PROJECTION				<h1 style="color: red; margin: 0;">LBTEK</h1>			
	NAME	DATE	AMM5-2AC				
DRAWN	ZLI	MAR./6th/20	60mm CAGE MIRROR MOUNT WITH SM2 THREADED FOR ϕ 50.8mm OPTICS				
APPROVAL	HDE	MAR./6th/20	MATERIAL	WEIGHT	SCALE	REV	
FOR INFORMATION ONLY NOT FOR MANUFACTURING PURPOSES			N/A	0.585 Kg	1:2	B	