

M6X0.25 ADJUSTER SCREWS PROVIDES +/-3° TOTAL ANGULAR DISPLACEMENT (0.23° PER REVOLUTION) 2 PLACES 2.0mm [5/64in] HEX

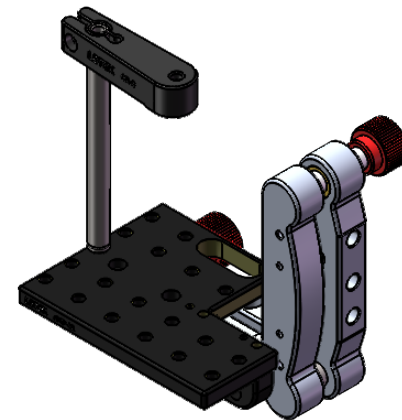
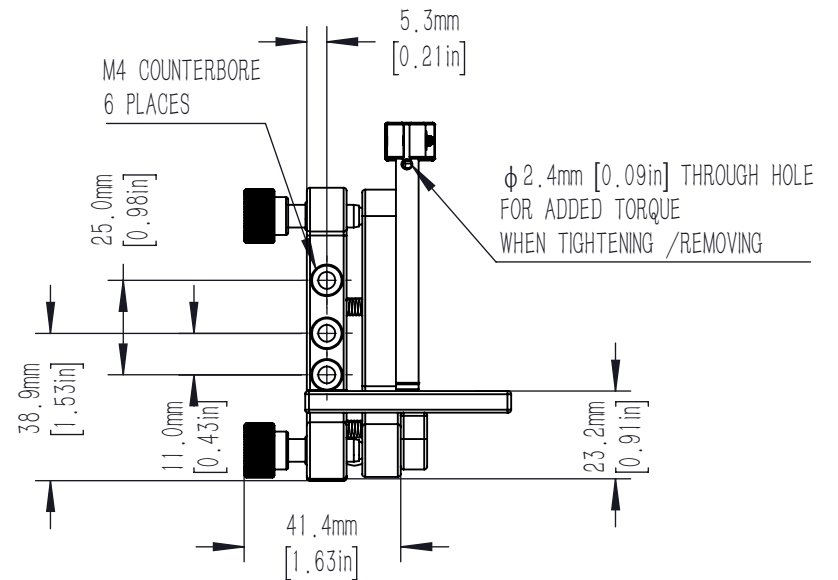
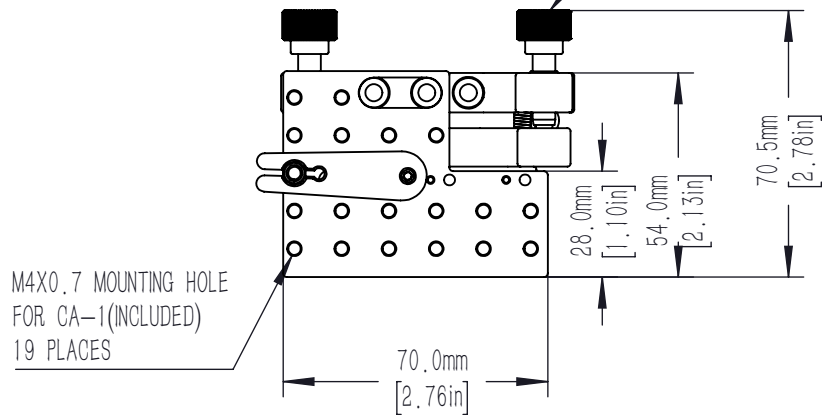

DRAWING PROJECTION			LBTEK			
NAME	DATE	AMP-2R				
DRAWN	CZH	AUG./15th/23	PRISM MOUNT, RIGHT-HANDED CONFIGURATION			
APPROVAL	ZXU	AUG./15th/23	MATERIAL	WEIGHT	SCALE	REV
FOR INFORMATION ONLY NOT FOR MANUFACTURING PURPOSES			N/A	0.272 Kg	1:2	C