

NUMBER	PART DESCRIPTION	MATERIAL
①	WEDGE	QUARTZ
②	WEDGE	QUARTZ

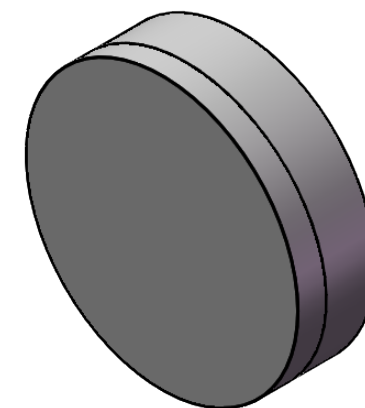
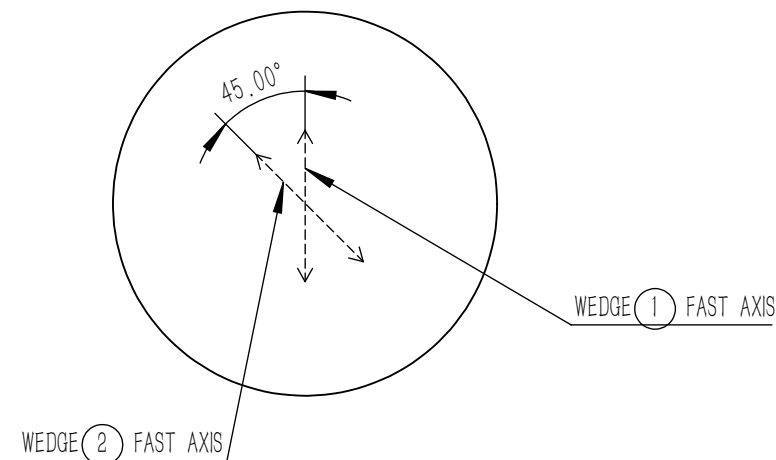
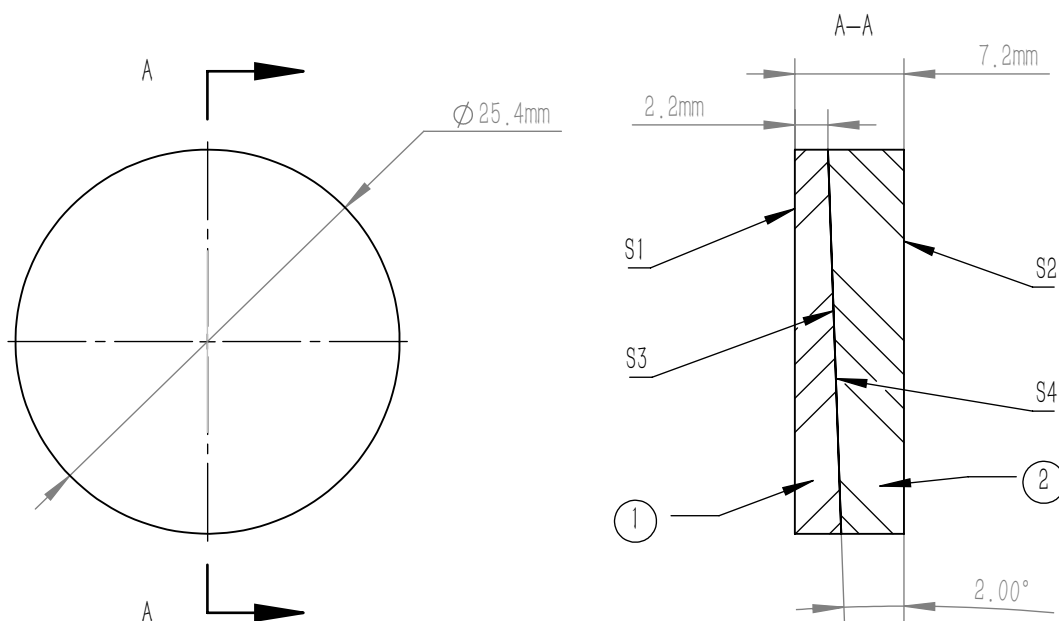

NOTES

1. OPERATION WAVELENGTH: 190 nm–2.5 μ m
2. COATING: UNCOATED, $T_{\text{abs}} > 80\%$ @ 190 nm–2.5 μ m, 0° AOI
3. GLUED(S3, S4): NOA61
4. SURFACE QUALITY(S1, S2): 20/10(S/D)
5. WAVEFRONT ERROR(RMS): $\lambda/4$ @ 633 nm
6. CLEAR APERTURE(S1, S2): $> 90\%$ CA
7. CHAMFER: 0.2 mm, 45°
8. THICKNESS TOLERANCE: ± 0.1 mm
9. DIAMETER TOLERANCE: +0.0 mm/–0.1 mm
10. WEDGE ANGLE TOLERANCE: $\pm 0.1^\circ$
11. PARALLELISM(S1, S2): < 1 arcmin
12. OTHER SURFACES: FINE GROUND
13. FAST AXIS ANGLE OF TWO WEDGES: 45° $\pm 1^\circ$
14. FAST AXIS MARK ON THE EDGE OF THE WEDGE

DRAWING PROJECTION			LBTEK			
	NAME	DATE				
DRAWN	LZHOU	Aug./26th/24	ACHROMATIC DEPOLARIZER $\varnothing 25.4$ mm, UNCOATED			
APPROVAL	WCHENG	Aug./26th/24	MATERIAL	WEIGHT	SCALE	REV
FOR INFORMATION ONLY NOT FOR MANUFACTURING PURPOSES			QUARTZ	9.7 g	2:1	A