

SPLITTING COATING(BEVEL FACE IN THE TRIANGULAR PRISM WITH DOT)

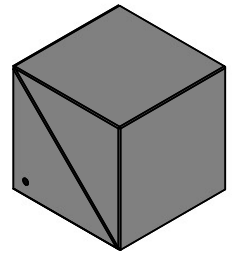
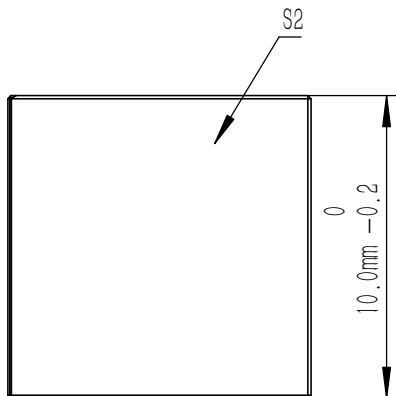
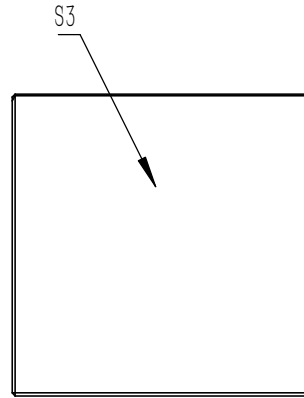

SCALE 2: 1

NOTES

1. CLEAR APERTURE: >80%CA
2. AR COATING(S1,S2,S3,S4):  $R_{avg} < 0.5\% @ 1064 \text{ nm}$   
(6° AOI, SINGLE SURFACE)
3. ANGLE TOLERANCE:  $\pm 5'$
4. COATING(S5): SPLITTING COATING  
 $T_{abs} = (87 \pm 10) \%$ ,  $R_{abs} = (7 + 10/-7) \%$ ;  $|T_s - T_p| < 10\%$   
and  $|R_s - R_p| < 10\%$ ;  $T_{abs} + R_{abs} > 85\%$
5. GLUED(S5,S6): NOA61
6. SPLIT RATIO(R:T): 10:90
7. TRANSMITTED BEAM DEVIATION:  $0^\circ \pm 5 \text{ arcmin}$
8. REFLECTED BEAM DEVIATION:  $90^\circ \pm 5 \text{ arcmin}$
9. SURFACE QUALITY(S1,S2,S3,S4): 40/20(S/D)
10. WAVEFRONT ERROR(RMS):  $\lambda/4 @ 633 \text{ nm}$
11. SURFACE FLATNESS(S1,S2,S3,S4):  $\lambda/4 @ 633 \text{ nm}$
12. OTHER SURFACES: FINE GROUND
13. CHAMFER: 0.2 mm, 45°

DRAWING PROJECTION			<b>LBTEK</b>			
	NAME	DATE	<b>BS1119-1064</b>			
DRAWN	LZHOU	Aug./12th/24	BEAM SPLITTER L=10.0 mm, R:T=10:90@1064 nm			
APPROVAL	WCHENG	Aug./12th/24	MATERIAL	WEIGHT	SCALE	REV
FOR INFORMATION ONLY NOT FOR MANUFACTURING PURPOSES			N-BK7	2.5 g	4:1	C