

SCALE 2: 1

NOTES

1. CLEAR APERTURE: >80%CA
2. AR COATING(S1, S2, S3, S4): $R_{avg} < 0.5\%$ @ 700 nm-1100 nm (6° AOI, SINGLE SURFACE)
3. ANGLE TOLERANCE: $\pm 5'$
4. COATING(S5): SPLITTING COATING
 $T_{abs} = (62 \pm 10)\%$, $R_{abs} = (27 \pm 10)\%$;
 $|T_s - T_p| < 10\%$, $|R_s - R_p| < 10\%$;
 $T_{abs} + R_{abs} > 80\%$
5. GLUED(S5, S6): NOA61
6. SPLIT RATIO(R:T): 30:70
7. TRANSMITTED BEAM DEVIATION: $0^\circ \pm 5$ arcmin
8. REFLECTED BEAM DEVIATION: $90^\circ \pm 5$ arcmin
9. SURFACE QUALITY(S1, S2, S3, S4): 40/20(S/D)
10. WAVEFRONT ERROR(RMS): $\lambda/4$ @ 633 nm
11. SURFACE FLATNESS(S1, S2, S3, S4): $\lambda/6$ @ 633 nm
12. OTHER SURFACES: FINE GROUND
13. CHAMFER: 0.2 mm, 45

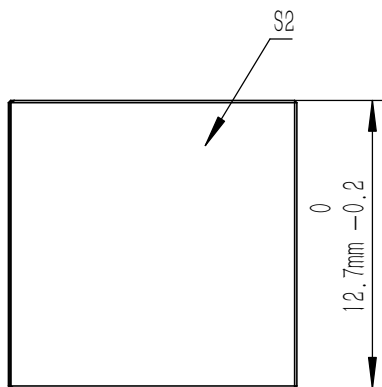

DRAWING PROJECTION			LBTEK			
	NAME	DATE	BS1237-B			
DRAWN	LZHOU	Aug./12th/24	BEAM SPLITTER L=12.7 mm, R:T=30:70 @ 700 nm-1100 nm			
APPROVAL	WCHENG	Aug./12th/24	MATERIAL	WEIGHT	SCALE	REV
FOR INFORMATION ONLY NOT FOR MANUFACTURING PURPOSES			N-BK7	5.1 g	3:1	A