

SCALE 1: 1

NOTES

1. CLEAR APERTURE: >80%CA
2. AR COATING(S1,S2,S3,S4):  $R_{avg} < 0.5\%$ @1100 nm-1600 nm (6° AOI, SINGLE SURFACE)
3. ANGLE TOLERANCE:  $\pm 5'$
4. COATING(S5): SPLITTING COATING  
 $T_{abs} = (7+10/-7)\%$ ,  $R_{abs} = (87 \pm 10)\%$ ;  
 $|T_s - T_p| < 10\%$ ,  $|R_s - R_p| < 10\%$ ;  $T_{abs} + R_{abs} > 85\%$
5. GLUED(S5,S6): NOA61
6. SPLIT RATIO(R:T): 90:10
7. TRANSMITTED BEAM DEVIATION:  $0^\circ \pm 5$  arcmin
8. REFLECTED BEAM DEVIATION:  $90^\circ \pm 5$  arcmin
9. SURFACE QUALITY(S1,S2,S3,S4): 40/20(S/D)
10. WAVEFRONT ERROR(RMS):  $\lambda/4$ @633 nm
11. SURFACE FLATNESS(S1,S2,S3,S4):  $\lambda/6$ @633 nm
12. OTHER SURFACES: FINE GROUND
13. CHAMFER: 0.2 mm, 45°

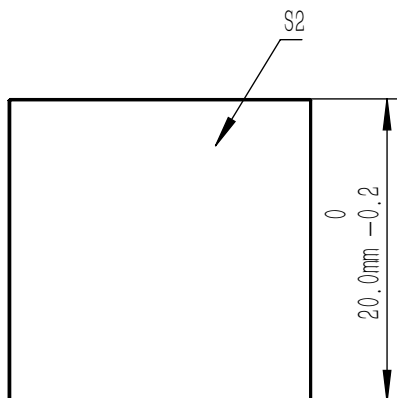

DRAWING PROJECTION			<b>LBTEK</b>			
	NAME	DATE				
DRAWN	LZHOU	Aug./12th/24	BEAM SPLITTER L=20.0 mm,R:T=90:10@1100 nm-1600 nm			
APPROVAL	WCHENG	Aug./12th/24	MATERIAL	WEIGHT	SCALE	REV
FOR INFORMATION ONLY NOT FOR MANUFACTURING PURPOSES			N-BK7	20.1 g	2:1	B