

SPLITTING COATING(BEVEL FACE IN THE TRIANGULAR PRISM WITH DOT)

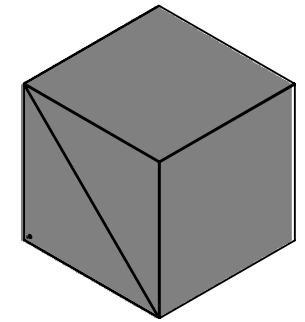
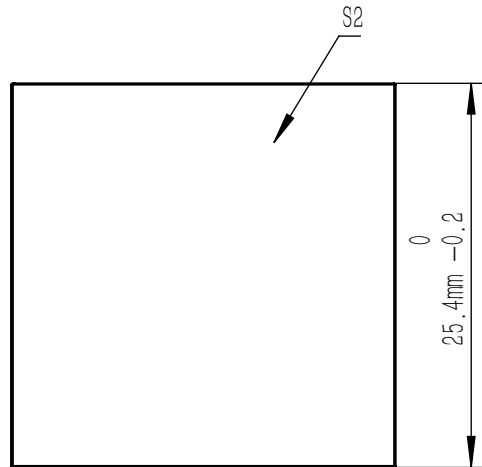
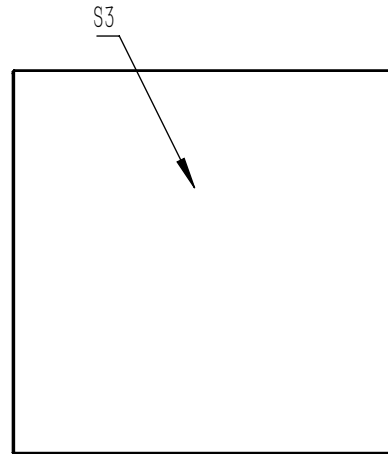

SCALE 1: 1

NOTES

1. CLEAR APERTURE: >80%CA
2. AR COATING(S1, S2, S3, S4):  $R_{avg} < 0.5\%$ @700 nm-1100 nm (6° AOI, SINGLE SURFACE)
3. ANGLE TOLERANCE:  $\pm 5'$
4. COATING(S5): SPLITTING COATING  
 $T_{abs} = (90 \pm 10)\%$ ,  $R_{abs} = (10 \pm 5)\%$ ;  
 $|T_s - T_p| < 10\%$ ,  $|R_s - R_p| < 5\%$ ;  $T_{abs} + R_{abs} > 90\%$
5. GLUED(S5, S6): NOA61
6. SPLIT RATIO(R:T): 10:90
7. TRANSMITTED BEAM DEVIATION:  $0^\circ \pm 5$  arcmin
8. REFLECTED BEAM DEVIATION:  $90^\circ \pm 5$  arcmin
9. SURFACE QUALITY(S1, S2, S3, S4): 40/20(S/D)
10. WAVEFRONT ERROR(RMS):  $\lambda/4$ @633 nm
11. SURFACE FLATNESS(S1, S2, S3, S4):  $\lambda/4$ @633 nm
12. OTHER SURFACES: FINE GROUND
13. CHAMFER: 0.2 mm, 45°

DRAWING PROJECTION			<b>LBTEK</b>			
NAME	DATE					
			BS1419-B			
DRAWN	LZHOU	Aug./12th/24	BEAM SPLITTER L=25.4 mm, R:T=10:90@700 nm-1100 nm			
APPROVAL	WCHENG	Aug./12th/24	MATERIAL	WEIGHT	SCALE	REV
FOR INFORMATION ONLY NOT FOR MANUFACTURING PURPOSES			N-BK7	41.1 g	2:1	D