

SCALE 1: 1

SPLITTING COATING(BEVEL FACE IN THE TRIANGULAR PRISM WITH DOT)

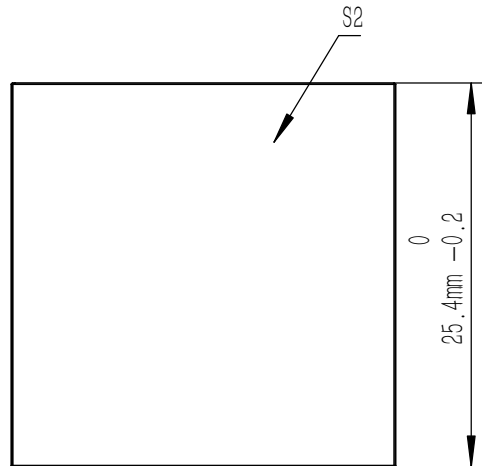

NOTES

1. CLEAR APERTURE: 80% CA
2. AR COATING(S1, S2, S3, S4): $R_{avg} < 0.5\%$ @ 400 nm-700 nm (6° AOI, SINGLE SURFACE)
3. ANGLE TOLERANCE: $\pm 5'$
4. COATING(S5): SPLITTING COATING
 $T_{abs} = (27 \pm 10)\%$, $R_{abs} = (60 + 10 / -20)\%$, $T_{abs} + R_{abs} > 70\%$ @ 400 nm-550 nm;
 $T_{abs} = (27 \pm 10)\%$, $R_{abs} = (67 + 5 / -15)\%$, $T_{abs} + R_{abs} > 85\%$ @ 550 nm-700 nm;
 $|T_s - T_p| < 10\%$, $|R_s - R_p| < 10\%$;
5. GLUED(S5, S6): NOA61
6. SPLIT RATIO(R: T): 70:30
7. TRANSMITTED BEAM DEVIATION: $0^\circ \pm 5$ arcmin
8. REFLECTED BEAM DEVIATION: $90^\circ \pm 5$ arcmin
9. SURFACE QUALITY(S1, S2, S3, S4): 40/20(S/D)
10. WAVEFRONT ERROR: $\lambda/4$ @ 633 nm
11. SURFACE FLATNESS(S1, S2, S3, S4): $\lambda/6$ @ 633 nm
12. OTHER SURFACES: FINE GROUND
13. CHAMFER: 0.2 mm, 45°

DRAWING PROJECTION			LBTEK			
	NAME	DATE				
DRAWN	LZHOU	Aug. /12th/24	BEAM SPLITTER L=25.4 mm, R:T=70:30@400 nm-700 nm			
APPROVAL	WCHENG	Aug. /12th/24	MATERIAL	WEIGHT	SCALE	REV
FOR INFORMATION ONLY NOT FOR MANUFACTURING PURPOSES			N-BK7	41.1 g	2:1	B