

SPLITTING COATING(BEVEL FACE IN THE TRIANGULAR PRISM WITH DOT)

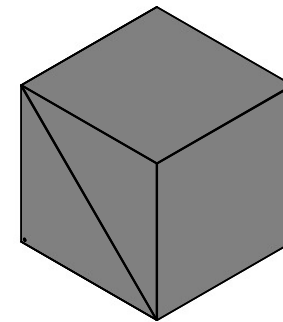
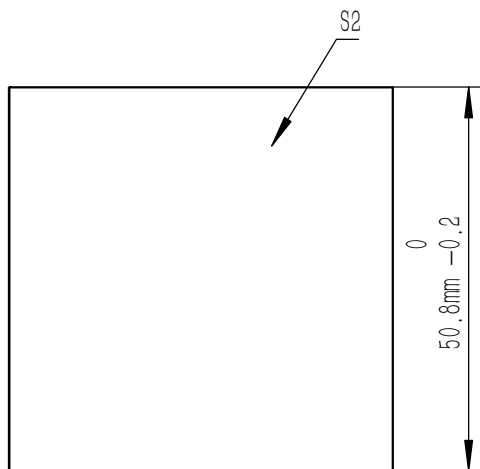
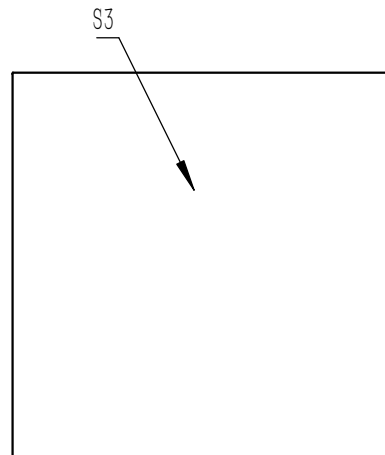

SCALE 1: 2

NOTES

1. CLEAR APERTURE: 80% CA
2. AR COATING(S1, S2, S3, S4):  $R_{avg} < 0.5\%$  @ 400 nm-700 nm (6° AOI, SINGLE SURFACE)
3. DIAMETER TOLERANCE:  $+0.0/-0.2$  mm
4. ANGLE TOLERANCE:  $\pm 5'$
5. COATING(S5): SPLITTING COATING  
 $T_{abs} = (47 \pm 10)\%$ ,  $R_{abs} = (47 \pm 10)\%$ ,  $T_{abs} + R_{abs} > 85\%$   
 $|T_s - T_p| < 10\%$ ,  $|R_s - R_p| < 10\%$
6. GLUED(S5, S6): NOA61
7. SPLIT RATIO(R: T): 50:50
8. TRANSMITTED BEAM DEVIATION:  $0^\circ \pm 5$  arcmin
9. REFLECTED BEAM DEVIATION:  $90^\circ \pm 5$  arcmin
10. SURFACE QUALITY(S1, S2, S3, S4): 40/20(S/D)
11. WAVEFRONT ERROR:  $\lambda/4$  @ 633 nm
12. SURFACE FLATNESS(S1, S2, S3, S4):  $\lambda/4$  @ 633 nm
13. OTHER SURFACES: FINE GROUND
14. CHAMFER: 0.2 mm, 45°

DRAWING PROJECTION			<b>LBTEK</b>			
NAME	DATE					
			<b>BS1555-A</b>			
DRAWN	LZHOU	Aug./12th/24	BEAM SPLITTER L=50.8 mm, R:T=50:50@400 nm-700 nm			
APPROVAL	WCHENG	Aug./12th/24	MATERIAL	WEIGHT	SCALE	REV
FOR INFORMATION ONLY NOT FOR MANUFACTURING PURPOSES			N-BK7	329 g	1:1	B