

	ITEM	MATERIAL
A	NEUTRAL DENSITY FILTER	UV FUSED SILICA
B	COAXIAL PLATES & MOUNTING RING	6061-T6 ALUMINUM
C	COAXIAL ASSEMBLY RODS	STAINLESS STEEL

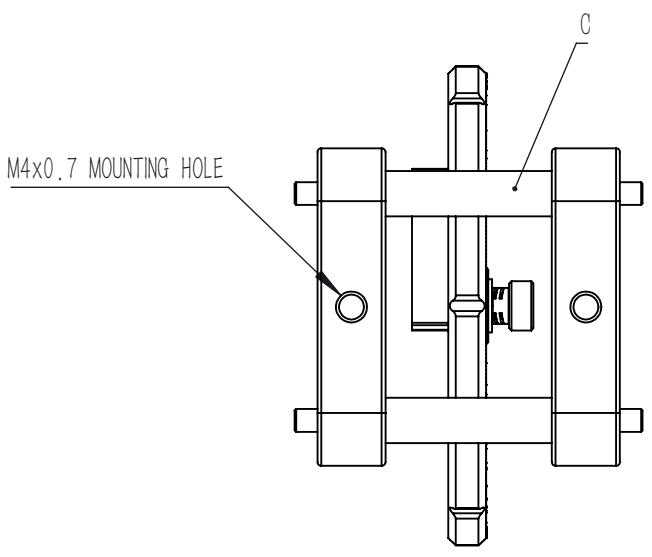

REMOVABLE M3x0.5 SET SCREW
1.5mm [0.06in] HEX
BOTH ENDS
3 PLACES

SM1 (Ø1.035"-40)
SERIES INTERNAL THREAD THRU
Ø23mm [0.91in] CLEAR APERTURE

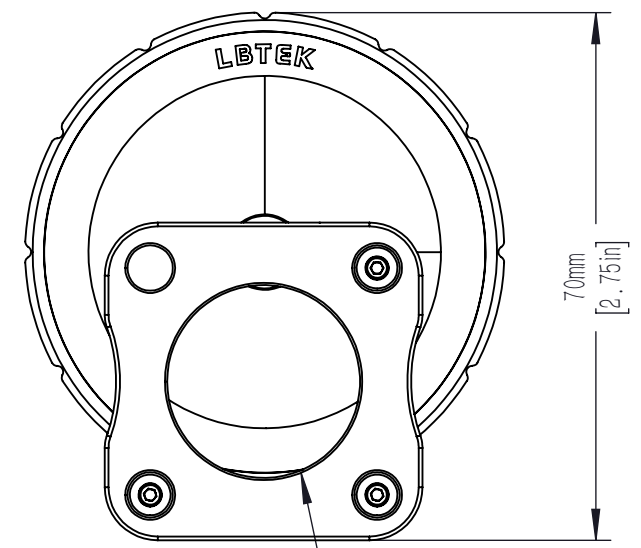
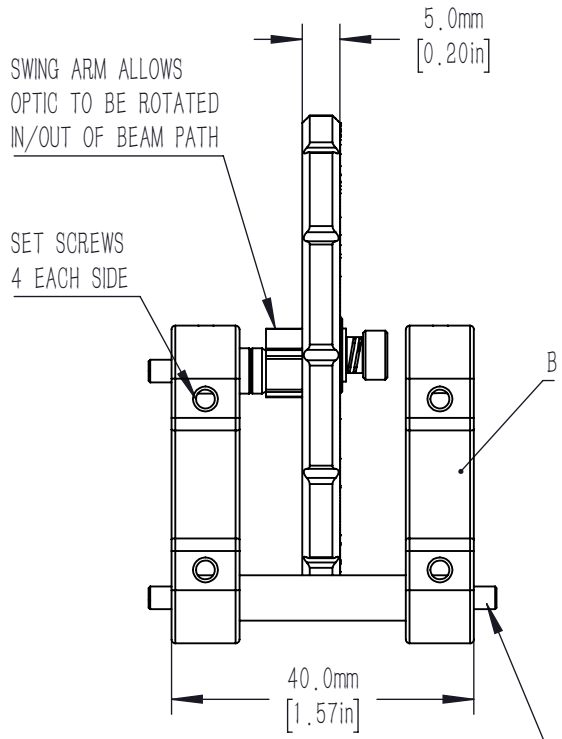
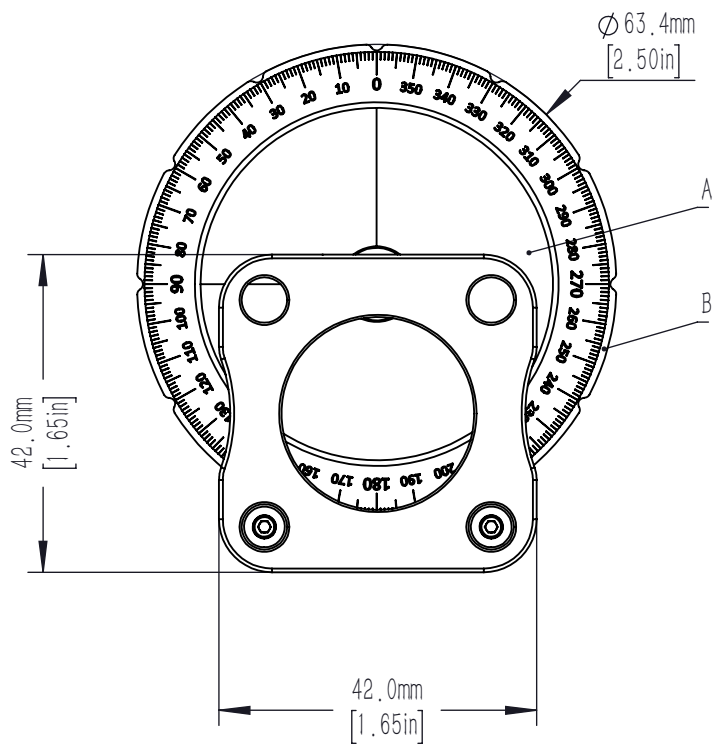
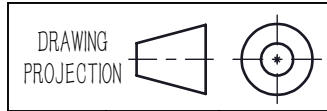

	NAME	DATE
DRAWN	KZH	JUN./23th/22
APPROVAL	ZXU	JUN./23th/22

LBTEK
www.lbtek.com

CNDFR-50C-2M						
COAXIAL SYSTEM NEUTRAL DENSITY FILTER WHEEL, OD=0-2.0						
	MATERIAL	WEIGHT	SCALE	REV		
	N/A	0.092 Kg	1:1	A		

FOR INFORMATION ONLY
NOT FOR MANUFACTURING PURPOSES