

LOCKING SCREW FOR ROTATION
2.0mm(0.08in) HEX
DO NOT OVERTIGHTEN
WHEN LOCKING

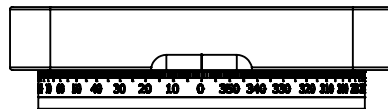
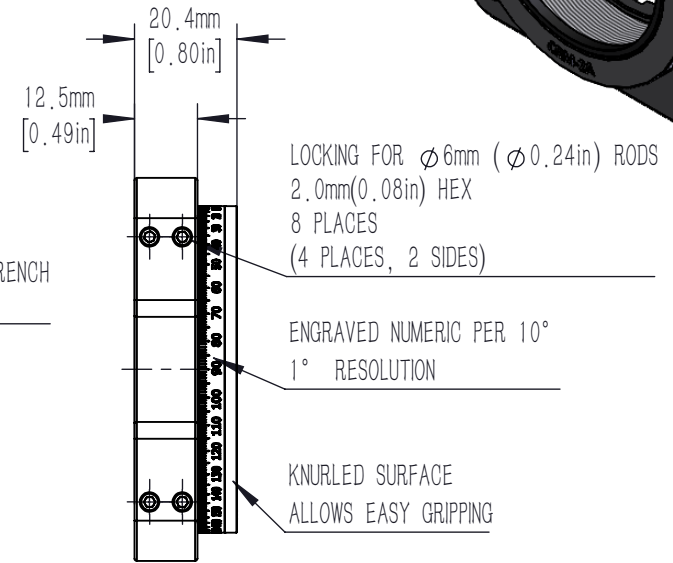
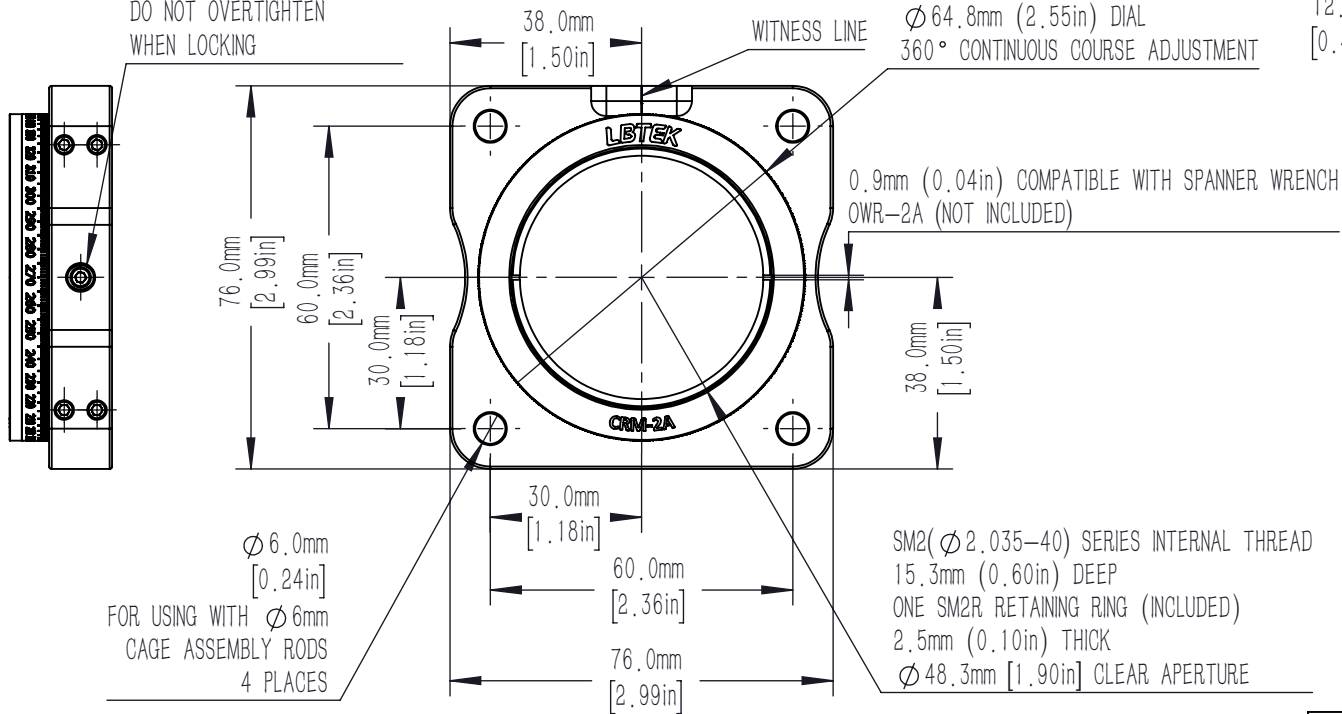

DRAWING PROJECTION			LBTEK			
	NAME	DATE				
DRAWN	CZH	JUN./27th/23	60mm CAGE ROTATION MOUNT			
APPROVAL	ZXU	JUN./27th/23	MATERIAL	WEIGHT	SCALE	REV
FOR INFORMATION ONLY NOT FOR MANUFACTURING PURPOSES			N/A	0.15 Kg	2:3	B