

LASER ENGRAVING GRADUATIONS PER 10mm
FOR MORE ACCURATE ADJUSTMENTS
1 mm RESOLUTION

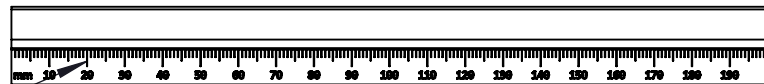

WAIST SHAPE HOLE FOR USE WITH
M6 [1/4in] CAP SCREW
3 PLACES

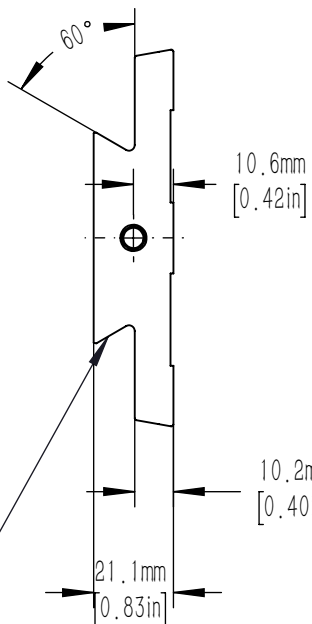

DOVETAIL FOR USE WITH
DR100F SERIES CARRIER

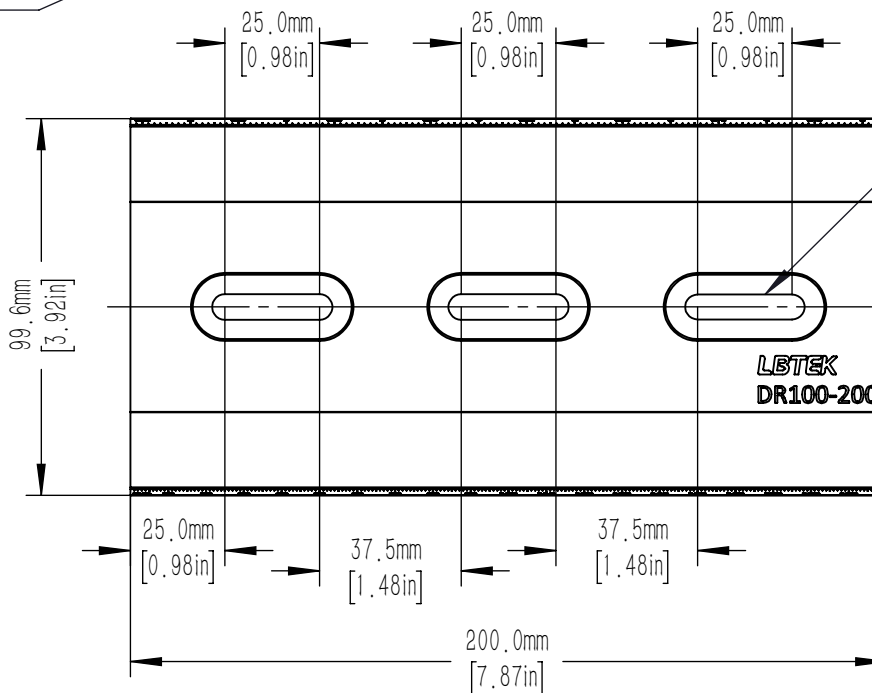

DOVEL PIN FOR
RAIL CONNECTING

LASER ENGRAVING GRADUATIONS PER 0.5in
FOR MORE ACCURATE ADJUSTMENTS
1/16 in RESOLUTION

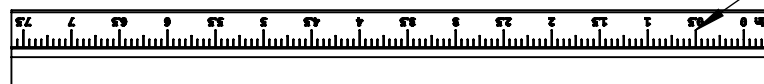

DRAWING PROJECTION			LBTEK			
	NAME	DATE	DR100-200			
DRAWN	SSO	MAR./6th/25	PRECISION 100MM DOVETAIL-TYPE OPTICAL GUIDE RAIL			
APPROVAL	YLI	MAR./6th/25	MATERIAL	WEIGHT	SCALE	REV
FOR INFORMATION ONLY NOT FOR MANUFACTURING PURPOSES			N/A	0.751 Kg	1:2	A