

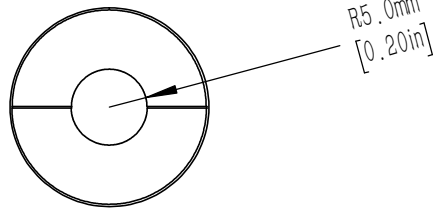

SMI EXTERNAL THREAD

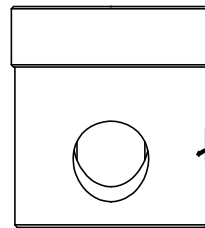

THE ARROW POINTS TO THE THREAD DIRECTION AND IS PERPENDICULAR TO THE ENGRAVED LINE

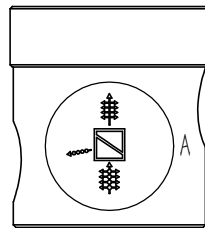
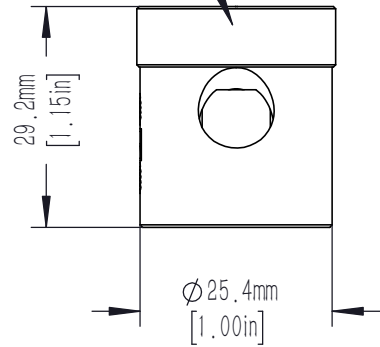
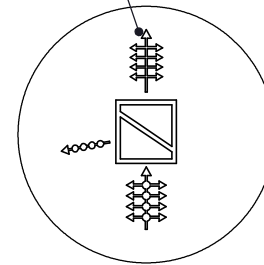

DRAWING OF PARTIAL ENLARGEMENT A SCALE 2:1

ENGRAVED LINE IS PARALLEL TO THE GROOVE

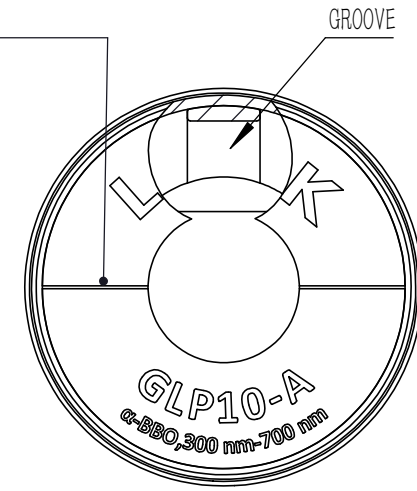

DRAWING OF PARTIAL ENLARGEMENT B SCALE 2:1



NOTES:

OPTICAL SPECS

1. SUBSTRATE MATERIAL:  $\alpha$ -BBO
2. WORKING WAVELENGTH: 300nm~700nm
3. EXTINGTION RATIO: 100,000:1
4. ENTRANCE/EXIT WINDOWS: 20-10 SCRATCH-DIG,  $\lambda/4@633$ nm
5. CLEAR APERTURE: >85% CA
6. BEAM DEVIATION: <3'
7. ACCEPTANCE ANGLE: >4° REF

MECHANICAL HOUSING SPECS

8. MATERIAL: ALUMINIUM 6061-T6
9. SURFACE PROCESS: HARD BLACK ANODIZING
10. CHAMFER: 0.3mm, 45°
11. NO OBVIOUS SCRATCH, NO BURRS, NO LEAKING GLUE
12. WITH PROTECTIVE FILM ATTACHED TO BOTH ENDS

DATA REQUIRE

13. PROVIDE WITNESS SAMPLE AND DATA FOR BATCH PRODUCT WITH COATING (TRANSMISSION, REFLECTION, EXTINGTION RATIO)
14. EACH PRODUCT FULLY SEPERATED WITH PROTECTIVE FOAM

DRAWING PROJECTION			<b>LBTEK</b> <a href="http://www.lbtek.com">www.lbtek.com</a>			
	NAME	DATE				
DRAWN	Lynne	JUN./27st/22	Glan-Laser crystal polarization prism, 300nm~700nm			
APPROVAL	ZBW	JUN./27st/22	MATERIAL	WEIGHT	SCALE	REV
FOR INFORMATION ONLY NOT FOR MANUFACTURING PURPOSES			N/A	Kg	1:1	ZB