

ACCEPTS ϕ 50.8mm [ϕ 2in] OPTICS
 MINIMUM 5.0mm [0.2in]
 ϕ 48mm [ϕ 1.89in] CLEAR APERTURE

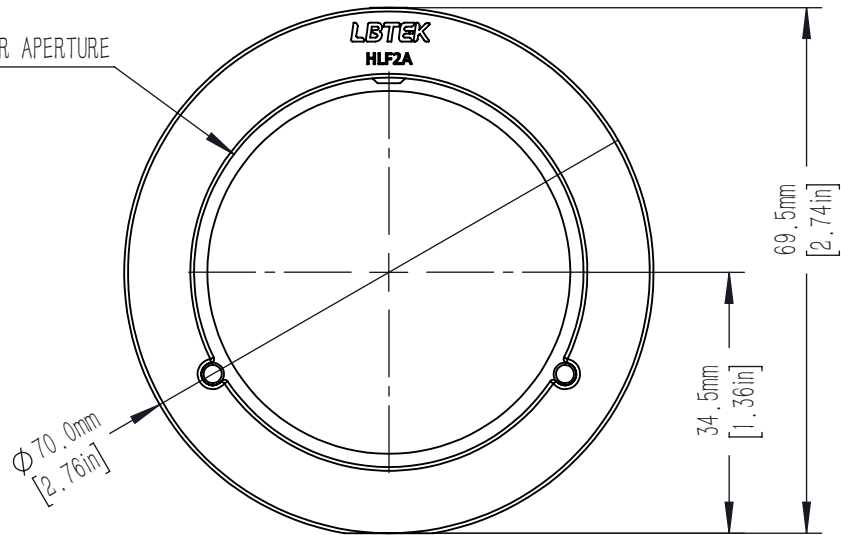

DRAWING PROJECTION			LBTEK			
	NAME	DATE				
DRAWN	ZLI	FEB./22th/20	LENS MOUNT FOR 50.8 mm OPTICS WITH UNTHREADED HOLE			
APPROVAL	DHE	FEB./22th/24	MATERIAL	WEIGHT	SCALE	REV
FOR INFORMATION ONLY NOT FOR MANUFACTURING PURPOSES			N/A	0.049 Kg	1:1	A