

	R	k	A4	A6	A8	A10	A12
S1	3.879161	-0.431729	-8.168899E-03	-1.995690E-04	2.200933E-04	-3.982084E-05	2.656612E-06
S2	-3.879161	-0.431729	8.168899E-03	1.995690E-04	-2.200933E-04	3.982084E-05	2.656612E-06

$$z = \frac{Y^2}{R(1 + \sqrt{1 - (1 + k)Y^2/R^2})} + A_4Y^4 + A_6Y^6 + A_8Y^8 + A_{10}Y^{10} + A_{12}Y^{12}$$

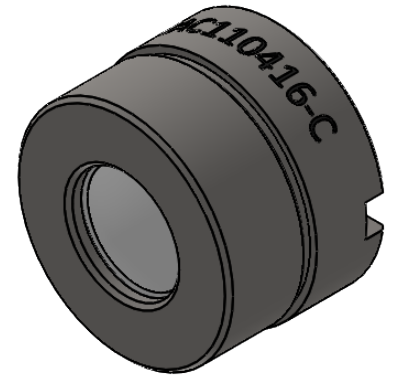
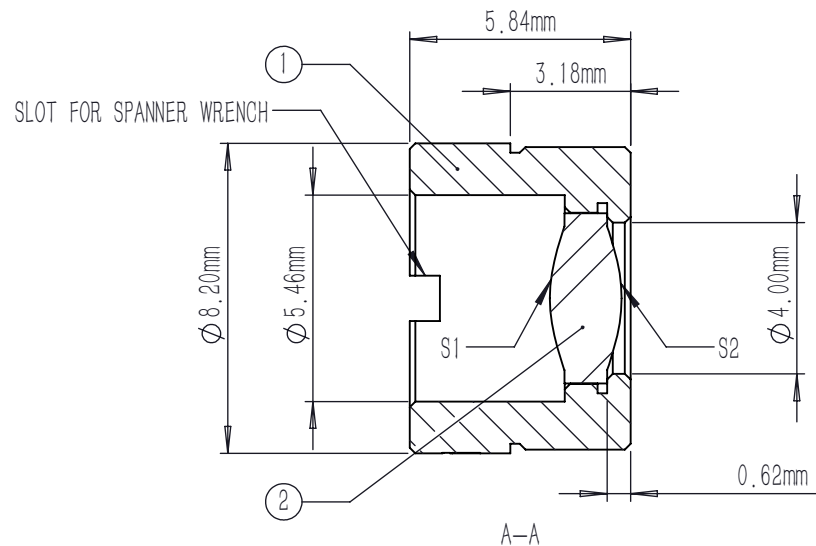
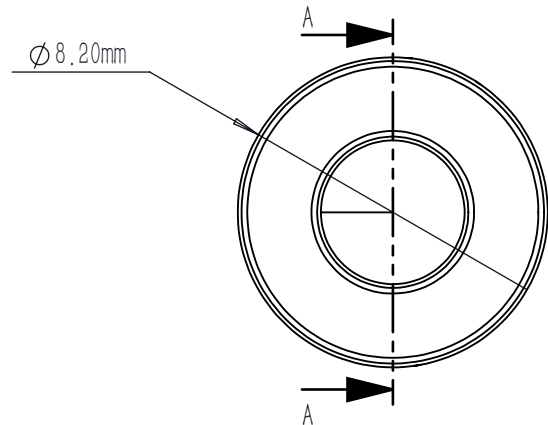

NOTES:

- MATERIAL: D-ZLAF52LA
- DESIGN WAVELENGTH: 830 nm
- WORKING WAVELENGTH: 1100 nm-1700 nm
- CLEAR APERTURE: (S1)  $\phi$ 3.60 mm, (S2)  $\phi$ 3.60 mm
- NUMERICAL APERTURE: 0.6
- FOCAL LENGTH: 2.7 mm
- FOCAL LENGTH TOLERANCE:  $\pm 1.0\%$
- BACK FOCAL LENGTH(REF):  $bf=2.1$  mm
- DIAMETER TOLERANCE:  $\pm 0.015$  mm
- THICKNESS TOLERANCE:  $\pm 0.04$  mm
- CHAMFER: 0.2 mm, 45°
- SURFACE QUALITY: 40-20 SCRATCH-DIG
- CENTRATION:  $<30$  arcmin
- MAXIMUM TEMPERATURE: 250 °C(482 °F)
- AR COATING(S1,S2):  $R_{avg} < 0.5\%$  @1100-1700 nm

	PART DESCRIPTION	MATERIAL
①	LENS MOUNT	303 STAINLESS STEEL
②	AC110416-C	D-ZLAF52LA

DRAWING PROJECTION			<b>LBTEK</b>			
NAME	DATE					
			MAC110416-C			
DRAWN	SHAN	APR./30th/24	ASPHERIC CONDENSER LENS			
APPROVAL	WCHENG	APR./30th/24	MATERIAL	WEIGHT	SCALE	REV
FOR INFORMATION ONLY NOT FOR MANUFACTURING PURPOSES			D-ZLAF52LA	1.47g	5:1	A