

	TYPE	SHAPE	CA	R	k	A4	A6	A8	A10	A12	A14	A16
S1	ASPHERE	CX	∅ 4.8	2.843569	-0.899542	2.313418E-3	6.313816E-5	7.072595E-7	-4.552089E-8	-8.836614E-9	-3.778708E-10	0
S2	PLANO	PL	∅ 3.39	PLANO	0	0	0	0	0	0	0	0

$$Z = \frac{Y^2}{R(1 + \sqrt{1 - (1 + K)Y^2 / R^2})} + \sum_i A_{2i} r^{2i}$$

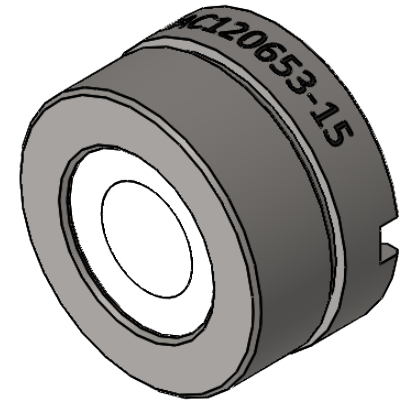
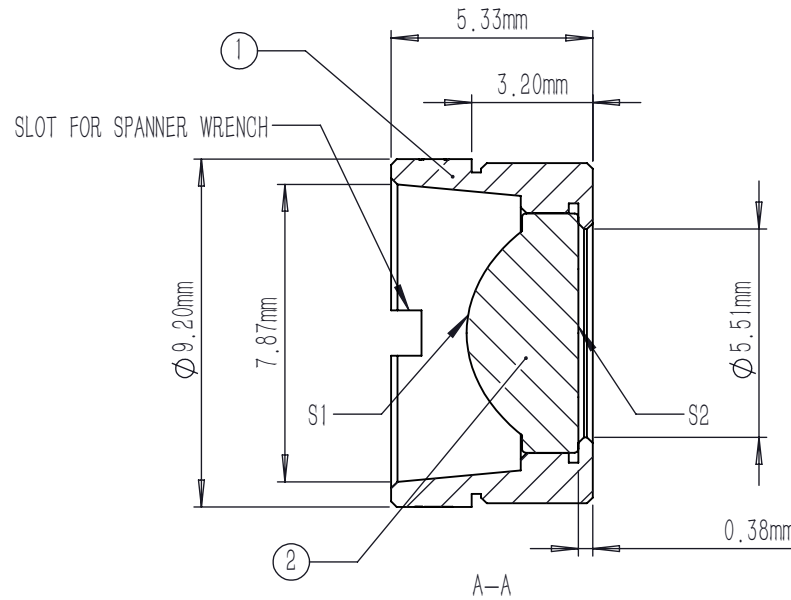
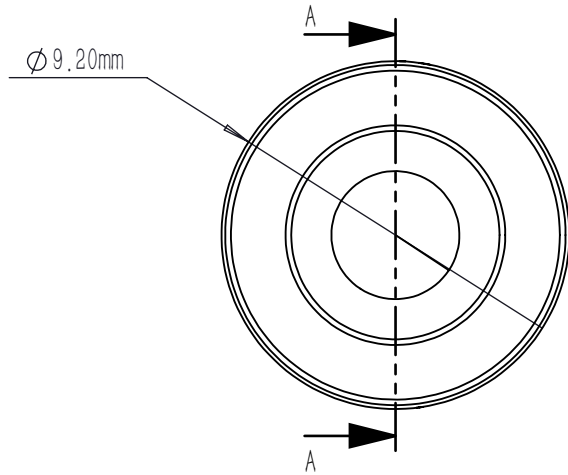

NOTES:

1. MATERIAL: D-LAK6
2. DESIGN WAVELENGTH: 410 nm
3. WORKING WAVELENGTH: 300 nm-2400 nm
4. CLEAR APERTURE: (S1) ∅ 4.80 mm, (S2) ∅ 3.39 mm
5. NUMERICAL APERTURE: 0.6
6. FOCAL LENGTH: 4.0 mm
7. FOCAL LENGTH TOLERANCE: ±1.0 %
8. BACK FOCAL LENGTH(REF): bf=2.7 mm
9. DIAMETER TOLERANCE: ±0.015 mm
10. THICKNESS TOLERANCE: ±0.02 mm
11. CHAMFER: 0.2 mm, 45 °
12. SURFACE QUALITY: 40-20 SCRATCH-DIG
13. CENTRATION: <30 arcmin
14. AR COATING: UNCOATED

	PART DESCRIPTION	MATERIAL
①	LENS MOUNT	303 STAINLESS STEEL
②	AC120653-15	D-LAK6

DRAWING PROJECTION				LBTEK			
	NAME	DATE	MAC120653-15				
DRAWN	SHAN	APR./30th/24	ASPHERIC CONDENSER LENS				
APPROVAL	WCHENG	APR./30th/24	MATERIAL	WEIGHT	SCALE	REV	
FOR INFORMATION ONLY NOT FOR MANUFACTURING PURPOSES			D-LAK6	1.23g	5:1	A	