

	TYPE	SHAPE	CA	R	k	A4	A6	A8	A10	A12	A14	A16
S1	ASPHERE	CX	∅4.8	2.859452	-1.035707	2.745915E-3	3.916906E-5	-2.023965E-8	-1.867865E-7	0	0	0
S2	PLANO	PL	∅3.45	PLANO	0	0	0	0	0	0	0	0

$$Z = \frac{Y^2}{R(1 + \sqrt{1 - (1 + K)Y^2 / R^2})} + \sum_i A_{2i} r^{2i}$$

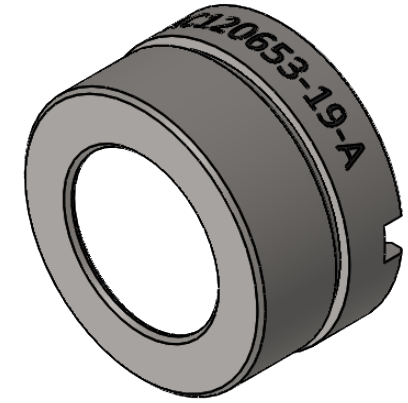
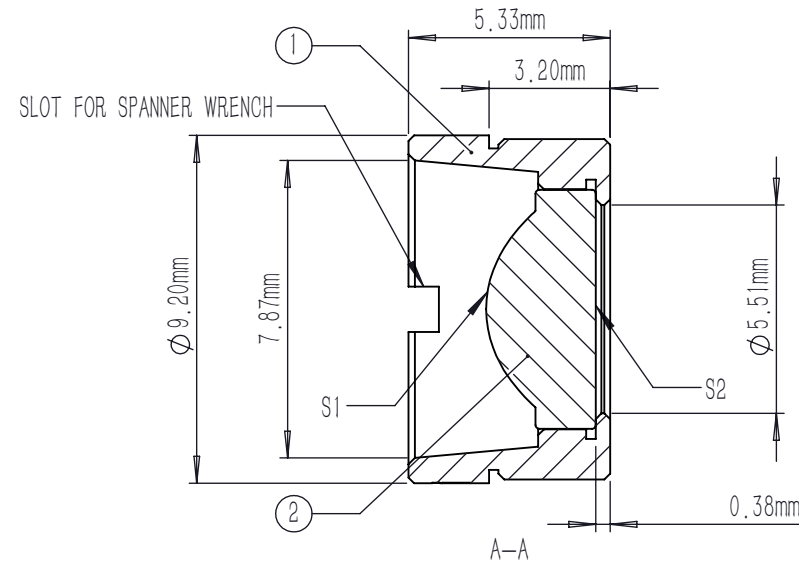
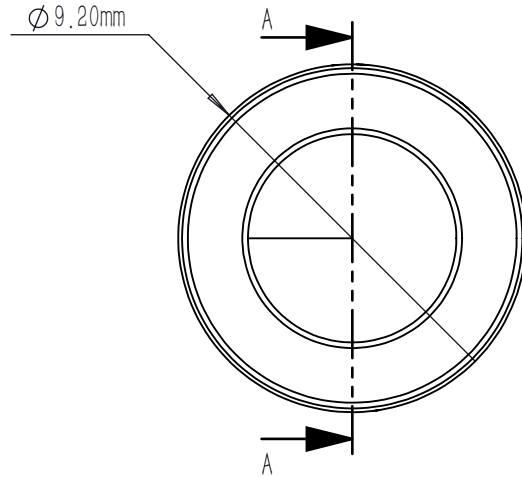

NOTES:

1. MATERIAL: D-LAK6
2. DESIGN WAVELENGTH: 408 nm
3. WORKING WAVELENGTH: 350 nm-700 nm
4. CLEAR APERTURE: (S1) ∅4.80 mm, (S2) ∅3.45 mm
5. NUMERICAL APERTURE: 0.6
6. FOCAL LENGTH: 4.0 mm
7. FOCAL LENGTH TOLERANCE: ±1.0 %
8. BACK FOCAL LENGTH(REF): bf=2.4 mm
9. DIAMETER TOLERANCE: ±0.015 mm
10. THICKNESS TOLERANCE: ±0.02 mm
11. CHAMFER: 0.2 mm, 45 °
12. SURFACE QUALITY: 40-20 SCRATCH-DIG
13. CENTRATION: <30 arcmin
14. AR COATING(S1,S2): Ravg<0.5 %@350-700 nm

	PART DESCRIPTION	MATERIAL
①	LENS MOUNT	303 STAINLESS STEEL
②	AC120653-19-A	D-LAK6

DRAWING PROJECTION			<b>LBTEK</b>			
NAME	DATE					
			MAC120653-19-A			
DRAWN	SHAN	APR./30th/24	ASPHERIC CONDENSER LENS			
APPROVAL	WCHENG	APR./30th/24	MATERIAL	WEIGHT	SCALE	REV
FOR INFORMATION ONLY NOT FOR MANUFACTURING PURPOSES			D-LAK6	1.23g	5:1	A