

ASPHERIC COEFFICIENTS

	R	K	A4	A6	A8	A10
S1	51.12	-0.575	-4.837e-11	-8.576e-12	-2.014e-15	-4.598e-19
S2	∞	-	-	-	-	-

ASPHERIC LENS EQUATION

$$z = \frac{Y^2}{R(1 + \sqrt{1 - (1 + k)Y^2/R^2})} + A_4Y^4 + A_6Y^6 + A_8Y^8 + A_{10}Y^{10}$$

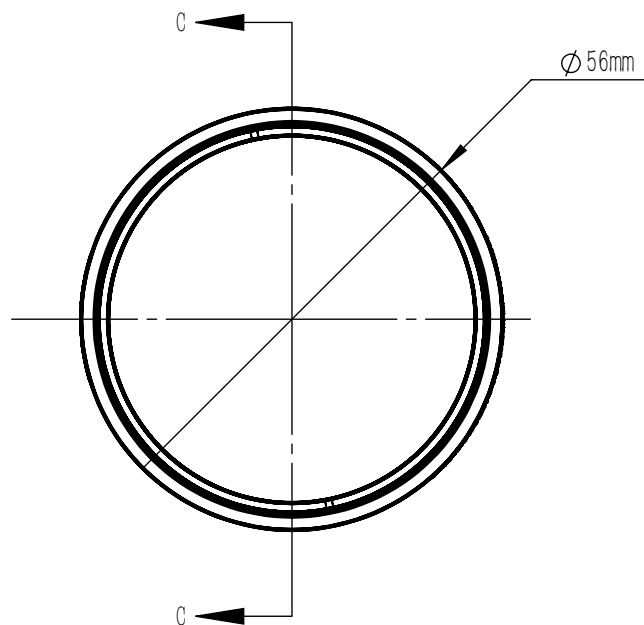

NOTES

- DESIGN WAVELENGTH: 780.0 nm
- NUMERICAL APERTURE: 0.22
- FOCAL LENGTH: 100.0 mm ± 1%
- BACK FOCAL LENGTH(REF): 93.4 mm
- CLEAR APERTURE: >90%CA
- DIAMETER TOLERANCE: +0.0/-0.1 mm
- THICKNESS TOLERANCE: ±0.1 mm
- CHAMFER: 0.2 mm, 45°
- WAVEFRONT ERROR(RMS): <0.5 μm
- SURFACE POWER(S1): ±7.5 μm
- SURFACE IRREGULARITY(S1): <3 FRINGES
- SURFACE FLATNESS(S2): λ/4@633 nm
- SURFACE QUALITY(S1,S2): 60/40 (S/D)
- CENTRATION: <3 arcmin
- AR COATING(S1,S2): Ravg<0.5 %@1050 nm-1700 nm, 6° AOI, Single Surface

	Part Description	Material
①	SM2R	ANODIZED ALUMINUM
②	SM2-12.5A	ANODIZED ALUMINUM
③	AC1811-C	N-BK7 or Equivalent Materials

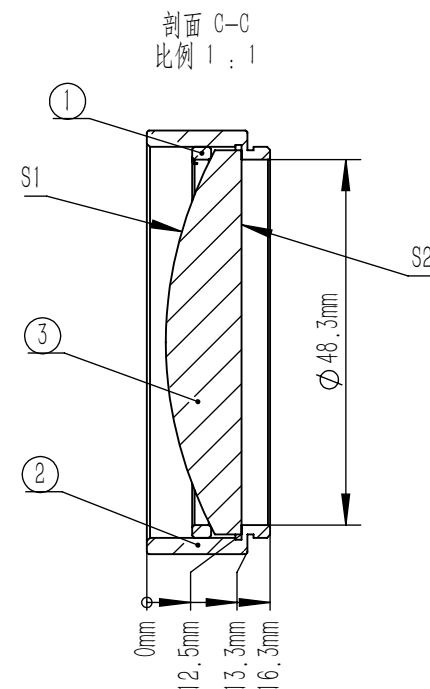

DRAWING PROJECTION			LBTEK			
NAME	DATE	MAC1811-C				
DRAWN	ZLIN	NOV./15th/25	ASPHERIC LENS			
APPROVAL	WCHENG	NOV./15th/25	MATERIAL	WEIGHT	SCALE	REV
FOR INFORMATION ONLY NOT FOR MANUFACTURING PURPOSES			N-BK7	157.00g	1:1	A