

ASPHERIC LENS EQUATION

	R	k	A4	A6	A8	A10	A12
S1	4.753124	-1.205071	5.3324183E-04	1.1162887E-05	-3.745566E-07	-7.6342017E-09	1.36022E-010
S2	-15.6494	-	-	-	-	-	-

ASPHERIC COEFFICIENTS

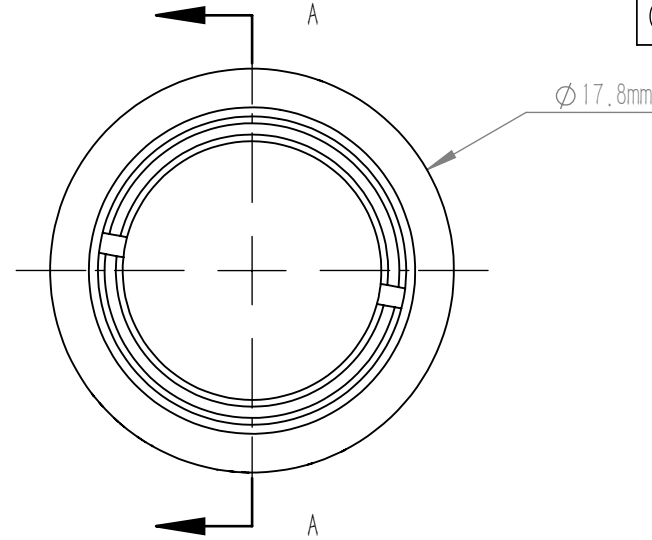
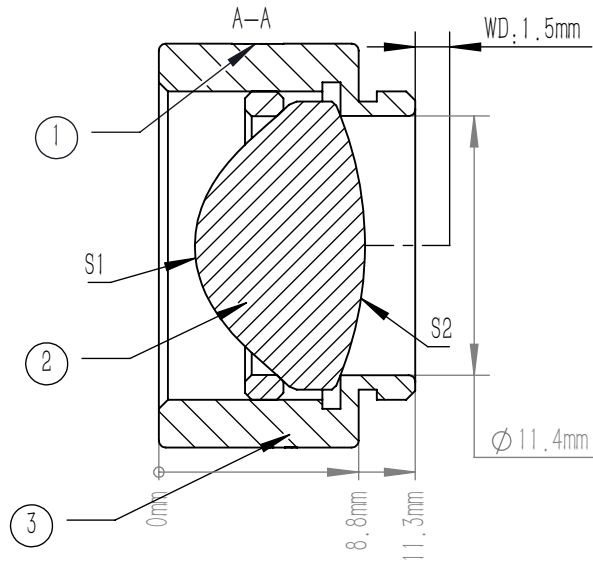

	PART DESCRIPTION	MATERIAL
①	SM05-8A	ANODIZED ALUMINIUM
②	AC4301-B	B270
③	SM05R	ANODIZED ALUMINIUM

NOTE

- DESIGN WAVELENGTH: 633.0 nm
- CLEAR APERTURE: >90%CA
- OPERATION WAVELENGTH: 700 nm-1100 nm
- NA: 0.78
- F/#: 0.70
- DIAMETER TOLERANCE: +0.0/-0.5 mm
- THICKNESS TOLERANCE: ±0.3 mm
- FOCAL LENGTH: 8.0 mm±8%
- BACK FOCAL LENGTH(REF): 3.7 mm
- SURFACE QUALITY(S1,S2): 80/50 (S/D)
- SURFACE FLATNESS(S2): λ/2@632.8 nm
- CENTRATION: <30 arcmin
- CHAMFER: <0.2 mm, 45°
- COATING (S1,S2) : AR COATING Ravg<0.5%@700 nm-1100 nm

$$z = \frac{y^2}{R(1 + \sqrt{1 - (1+k)Y^2/R^2})} + A_4Y^4 + A_6Y^6 + A_8Y^8 + A_{10}Y^{10} + A_{12}Y^{12}$$

DRAWING PROJECTION			LBTEK			
	NAME	DATE	MAC4301-B			
DRAWN	BSHU	Aug./5th/24	Ø 12.7 mm, F=8.0 mm, NA=0.78 ASPHERIC CONDENSER LENS AR COATING 700-1100 nm			
APPROVAL	WCHENG	Aug./5th/24	MATERIAL	WEIGHT	SCALE	REV
FOR INFORMATION ONLY NOT FOR MANUFACTURING PURPOSES			B270	9.84g	2:1	B