

ASPHERIC LENS EQUATION

	R	k	A4	A6	A8	A10
S1	8.818197	-0.9991715	8.6821674E-05	6.3760123E-08	2.407308E-09	-1.7189021E-11
S2	-69.99948	-	-	-	-	-

ASPHERIC COEFFICIENTS

	PART DESCRIPTION	MATERIAL
①	SM1-16.5A	ANODIZED ALUMINIUM
②	MAC4704-B	B270
③	SM1R	ANODIZED ALUMINIUM

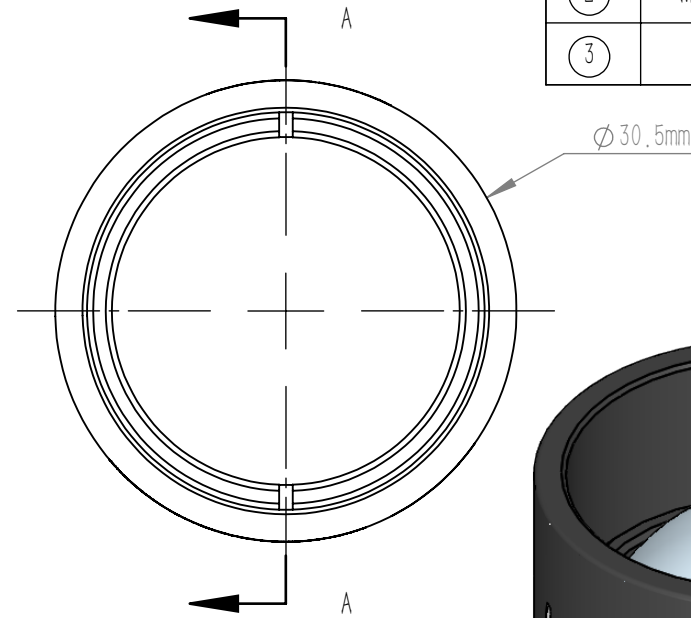
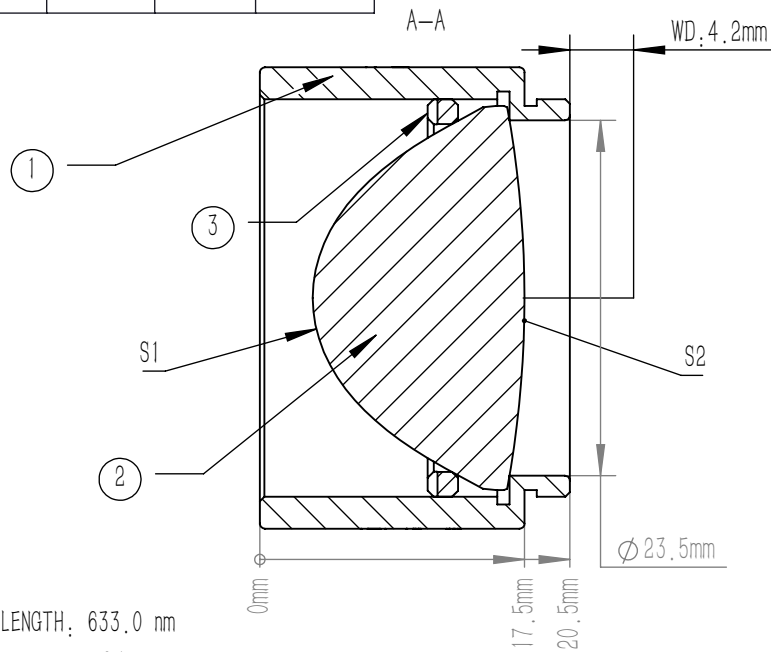

NOTE

- DESIGN WAVELENGTH: 633.0 nm
- CLEAR APERTURE: >90%CA
- OPERATION WAVELENGTH: 700 nm-1100 nm
- NA: 0.79
- F/#: 0.70
- DIAMETER TOLERANCE: +0.0/-0.5 mm
- THICKNESS TOLERANCE: ±0.3 mm
- FOCAL LENGTH: 16.0 mm±8%
- BACK FOCAL LENGTH(REF): 7.3 mm
- SURFACE QUALITY(S1,S2): 80/50 (S/D)
- SURFACE FLATNESS(S2): λ/2@632.8 nm
- CENTRATION: <30 arcmin
- CHAMFER: <0.2 mm, 45°
- COATING (S1,S2) : AR COATING Ravg<0.5%@700 nm-1100 nm

$$z = \frac{y^2}{R(1 + \sqrt{1 - (1+k)y^2/R^2})} + A_4Y^4 + A_6Y^6 + A_8Y^8 + A_{10}Y^{10}$$

DRAWING PROJECTION			LBTEK			
NAME	DATE	MAC4704-B				
DRAWN	BSHU	Aug./5th/24	Ø 25.4 mm, F=16.0 mm, NA=0.79 ASPHERIC CONDENSER LENS AR COATING 700-1100 nm			
APPROVAL	WCHENG	Aug./5th/24	MATERIAL	WEIGHT	SCALE	REV
FOR INFORMATION ONLY NOT FOR MANUFACTURING PURPOSES			B270	40.12g	2:1	B