

ASPHERIC COEFFICIENTS	R	K	A4	A6	A8	A10	A12	A14	A16
S1	15.54	-1.35	2.362e-05	-1.130e-08	-1.111e-11	-2.398e-14	3.036e-17	1.366e-19	-1.888e-22
S2	∞	-	-	-	-	-	-	-	-

	Part Description	Material
①	SM1R	ANODIZED ALUMINUM
②	SM1-12.5A	ANODIZED ALUMINUM
③	AC7606	S-LAH64 or Equivalent Materials

ASPHERIC LENS EQUATION

$$Z = \frac{Y^2}{R(1 + \sqrt{1 - (1 + K)Y^2/R^2})} + A_4Y^4 + A_6Y^6 + A_8Y^8 + A_{10}Y^{10} + A_{12}Y^{12} + A_{14}Y^{14} + A_{16}Y^{16}$$

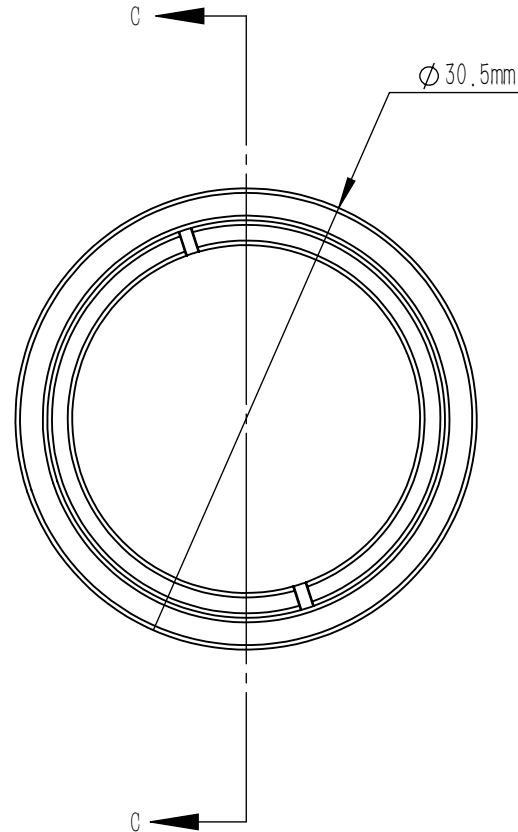

剖面 C-C

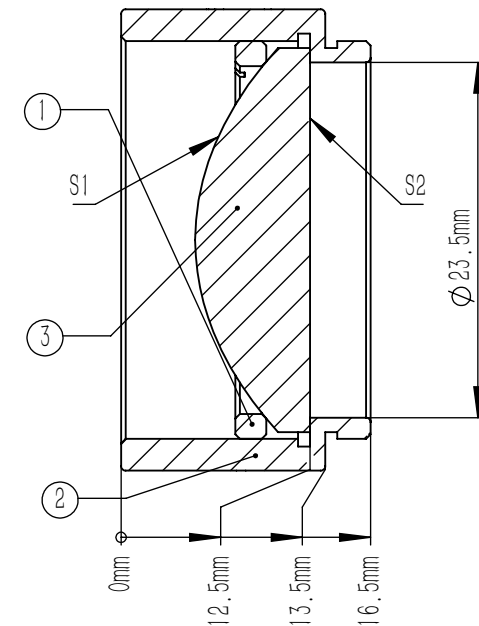

NOTES

- DESIGN WAVELENGTH: 780.0 nm
- NUMERICAL APERTURE: 0.5
- FOCAL LENGTH: 20.0 mm ± 1%
- BACK FOCAL LENGTH(REF): 15.7 mm
- CLEAR APERTURE: >90%CA
- DIAMETER TOLERANCE: +0.0/-0.1 mm
- THICKNESS TOLERANCE: ±0.1 mm
- CHAMFER: 0.2 mm, 45°
- WAVEFRONT ERROR(RMS): <0.5 μm
- SURFACE POWER(S1): ±7.5 μm
- SURFACE IRREGULARITY(S1): <3 FRINGES
- SURFACE FLATNESS(S2): λ/4@633 nm
- SURFACE QUALITY(S1,S2): 60/40 (S/D)
- CENTRATION: <3 arcmin
- AR COATING(S1,S2): UNCOATED

DRAWING PROJECTION				LBTEK			
NAME	DATE	MAC7606					
DRAWN	ZLIN	NOV./15th/25	ASPHERIC LENS				
APPROVAL	WCHENG	NOV./15th/25	MATERIAL	WEIGHT	SCALE	REV	
FOR INFORMATION ONLY NOT FOR MANUFACTURING PURPOSES			S-LAH64	29.13 g	2:1	A	