

ASPHERIC COEFFICIENTS

	R	K	A4	A6	A8	A10	A12
S1	24.861	-1.974	1.044e-05	-6.403e-09	-4.465e-12	8.835e-14	-2.968e-16
S2	∞	-	-	-	-		

ASPHERIC LENS EQUATION

$$Z = \frac{Y^2}{R(1 + \sqrt{1 - (1 + K)Y^2 / R^2})} + A_4Y^4 + A_6Y^6 + A_8Y^8 + A_{10}Y^{10} + A_{12}Y^{12}$$

	Part Description	Material
①	SM1R	ANODIZED ALUMINUM
②	SM1-8A	ANODIZED ALUMINUM
③	AC7612-B	S-LAH64 or Equivalent Materials

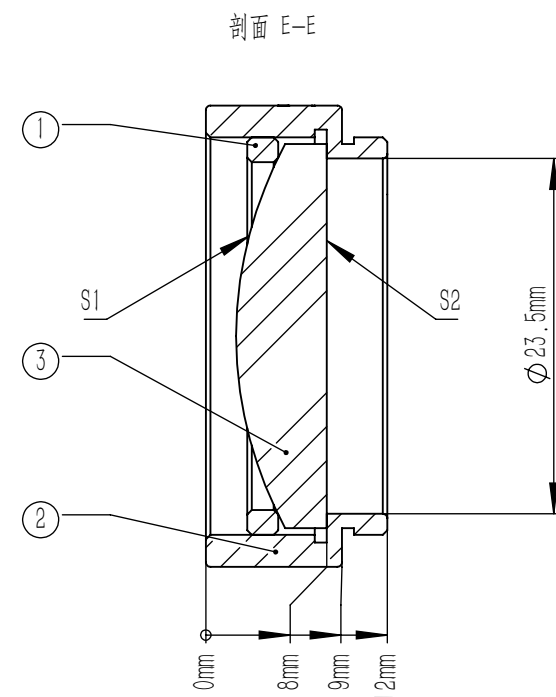
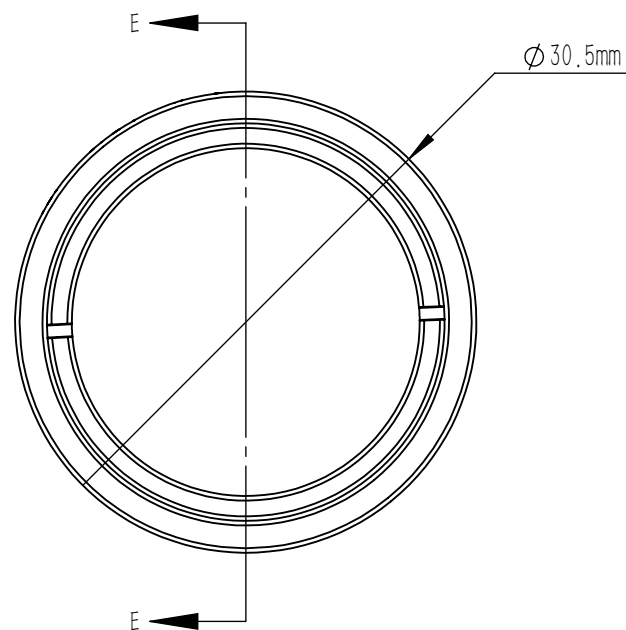

NOTES

- DESIGN WAVELENGTH: 780.0 nm
- NUMERICAL APERTURE: 0.34
- FOCAL LENGTH: 32.0 mm ± 1%
- BACK FOCAL LENGTH(REF): 29.0 mm
- CLEAR APERTURE: >90%CA
- DIAMETER TOLERANCE: +0.0/-0.1 mm
- THICKNESS TOLERANCE: ±0.1 mm
- CHAMFER: 0.2 mm, 45°
- WAVEFRONT ERROR(RMS): <0.5 μm
- SURFACE POWER(S1): ±7.5 μm
- SURFACE IRREGULARITY(S1): <3 FRINGES
- SURFACE FLATNESS(S2): λ/4@633 nm
- SURFACE QUALITY(S1,S2): 60/40 (S/D)
- CENTRATION: <3 arcmin
- AR COATING(S1,S2): Ravg<0.5%@700-1100 nm, 6°AOI, Single Surface

DRAWING PROJECTION				<b>LBTEK</b>			
NAME	DATE	MAC7612-B					
DRAWN	ZLIN	NOV./15th/25	ASPHERIC LENS				
APPROVAL	WCHENG	NOV./15th/25	MATERIAL	WEIGHT	SCALE	REV	
FOR INFORMATION ONLY NOT FOR MANUFACTURING PURPOSES			S-LAH64	23.49 g	2:1	A	