

	R	k	A4	A6	A8
S1	2.591249	-0.902951	2.903858E-03	1.043666E-04	3.714989E-06
S2	PLANO	-	-	-	-

$$z = \frac{Y^2}{R(1 + \sqrt{1 - (1+k)Y^2/R^2})} + A_4Y^4 + A_6Y^6 + A_8Y^8$$

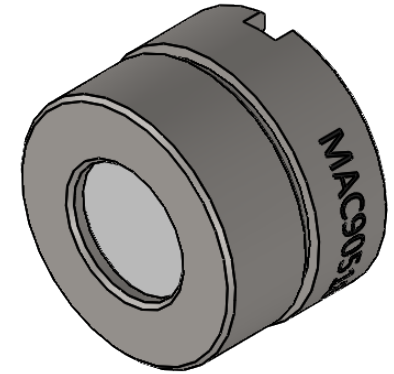
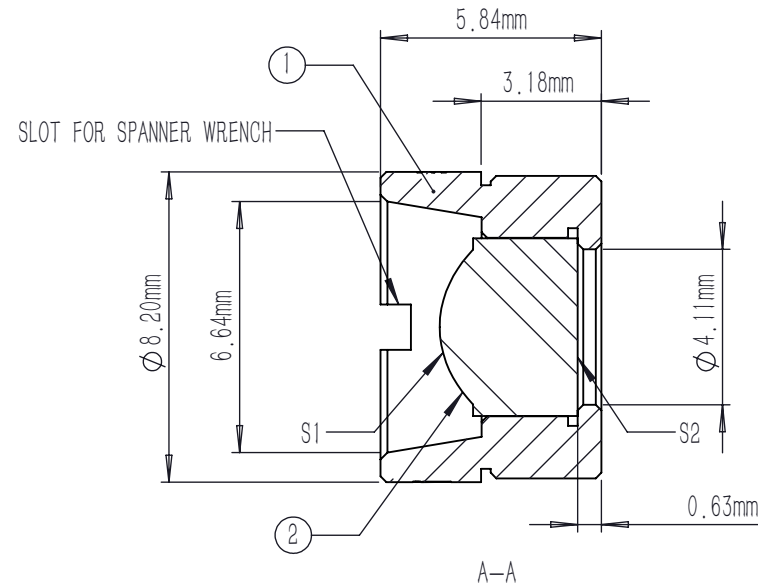
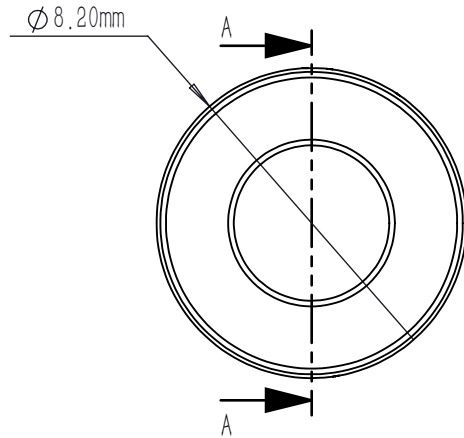

NOTES:

1. MATERIAL: D-ZK3
2. DESIGN WAVELENGTH: 980.0 nm
3. WORKING WAVELENGTH: 290 nm-2400 nm
4. CLEAR APERTURE: (S1) \varnothing 3.70 mm, (S2) \varnothing 2.05 mm
5. NUMERICAL APERTURE: 0.4
6. FOCAL LENGTH: 4.5 mm
7. FOCAL LENGTH TOLERANCE: $\pm 1.0\%$
8. BACK FOCAL LENGTH(REF): $bf=2.2$ mm
9. DIAMETER TOLERANCE: ± 0.015 mm
10. THICKNESS TOLERANCE: ± 0.04 mm
11. CHAMFER: 0.2 mm, 45°
12. SURFACE QUALITY: 40-20 SCRATCH-DIG
13. CENTRATION: <30 arcmin
14. MAXIMUM TEMPERATURE: 250 $^\circ$ C(482 $^\circ$ F)
15. AR COATING: UNCOATED

	PART DESCRIPTION	MATERIAL
①	LENS MOUNT	303 STAINLESS STEEL
②	AC90518	D-ZK3

DRAWING PROJECTION				LBTEK			
NAME	DATE	MAC90518					
DRAWN	SHAN	APR./30th/24	ASPHERIC CONDENSER LENS				
APPROVAL	WCHENG	APR./30th/24	MATERIAL	WEIGHT	SCALE	REV	
FOR INFORMATION ONLY NOT FOR MANUFACTURING PURPOSES			D-ZK3	1.42g	5:1	A	