

	TYPE	SHAPE	CA	R	k	A4	A6	A8	A10	A12	A14	A16
S1	ASPHERE	CX	∅5.00	2.725382	-0.542123	-2.077710E-5	-1.373930E-4	2.029328E-5	-2.961194E-6	0	0	0
S2	PLANO	PL	∅3.84	-2.979042	-12.105853	8.068905E-3	-1.725894E-3	1.839072E-4	-8.936267E-6	0	0	0

$$Z = \frac{Y^2}{R(1 + \sqrt{1 - (1 + K)Y^2 / R^2})} + \sum_i A_{2i} r^{2i}$$

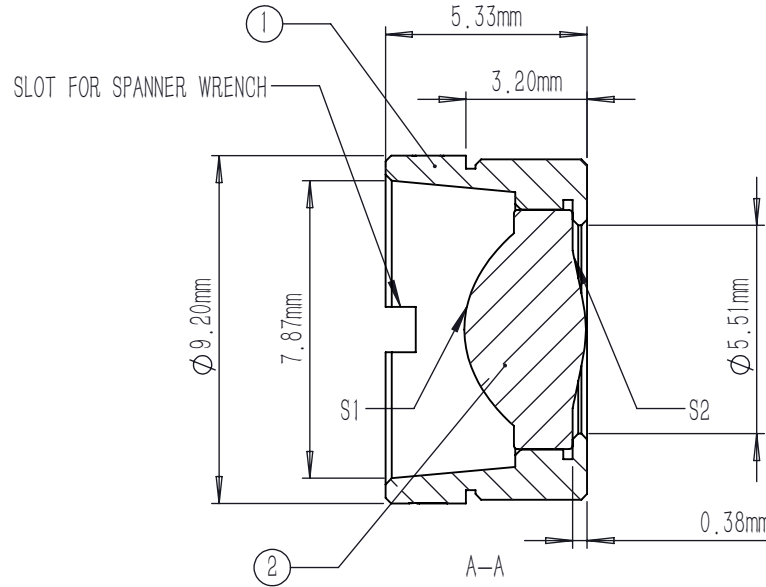
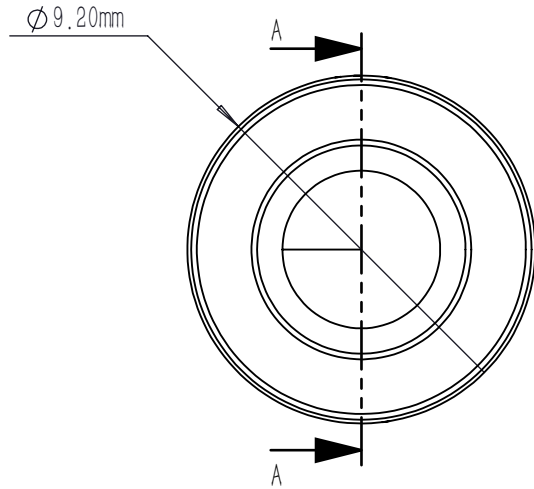

NOTES:

- MATERIAL: D-ZK3
- DESIGN WAVELENGTH: 830 nm
- WORKING WAVELENGTH: 350 nm-700 nm
- CLEAR APERTURE: (S1) ∅5.00 mm, (S2) ∅3.84 mm
- NUMERICAL APERTURE: 0.7
- FOCAL LENGTH: 3.1 mm
- FOCAL LENGTH TOLERANCE: ±1.0 %
- BACK FOCAL LENGTH(REF): bf=1.8 mm
- DIAMETER TOLERANCE: ±0.015 mm
- THICKNESS TOLERANCE: ±0.03 mm
- CHAMFER: 0.2 mm, 45 °
- SURFACE QUALITY: 40-20 SCRATCH-DIG
- CENTRATION: <30 arcmin
- MAXIMUM TEMPERATURE: 250 °C(482 °F)
- AR COATING(S1,S2): Ravg<0.5 %@350-700 nm

	PART DESCRIPTION	MATERIAL
①	LENS MOUNT	303 STAINLESS STEEL
②	AC90621-A	D-ZK3

DRAWING PROJECTION				LBTEK			
NAME	DATE	MAC90621-A					
DRAWN	SHAN	APR./30th/24	ASPHERIC CONDENSER LENS				
APPROVAL	WCHENG	APR./30th/24	MATERIAL	WEIGHT	SCALE	REV	
FOR INFORMATION ONLY NOT FOR MANUFACTURING PURPOSES			D-ZK3	1.19g	5:1	A	