

	TYPE	SHAPE	CA	R	k	A4	A6	A8	A10	A12	A14	A16
S1	ASPHERE	CX	∅5.20	6.428042	-0.578747	2.792924E-6	-3.958166E-7	-1.124255E-9	-3.446196E	0	0	0
S2	PLANO	PL	∅4.63	PLANO	0	0	0	0	0	0	0	0

$$Z = \frac{Y^2}{R(1 + \sqrt{1 - (1 + K)Y^2 / R^2})} + \sum_i A_{2i} r^{2i}$$

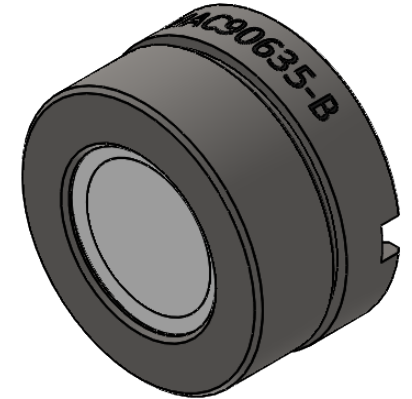
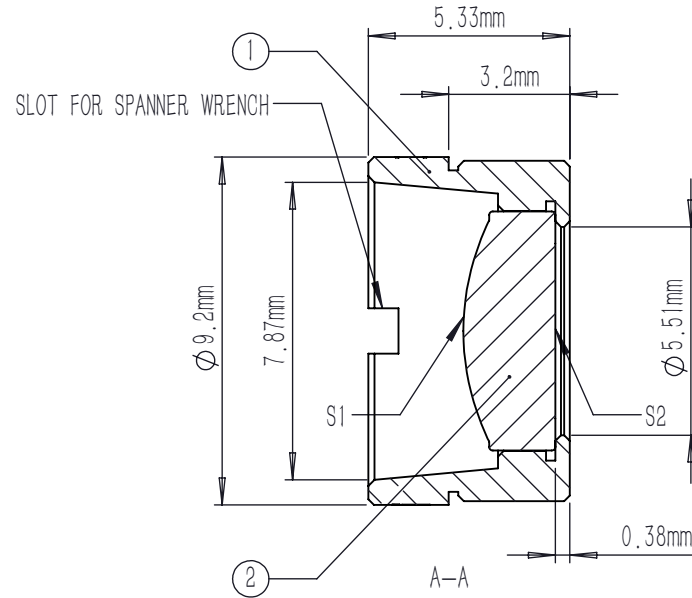
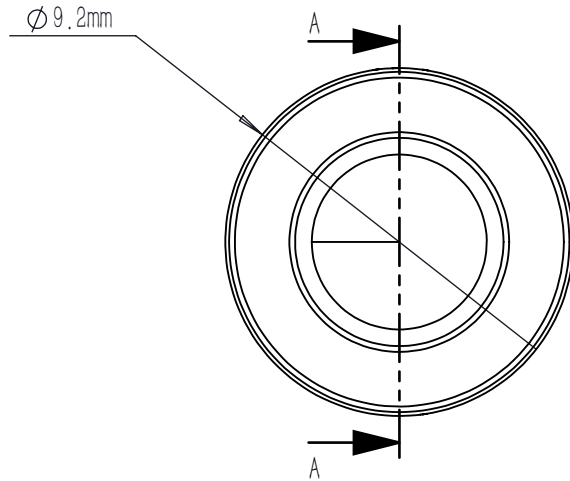

NOTES:

- MATERIAL: D-ZK3
- DESIGN WAVELENGTH: 780 nm
- WORKING WAVELENGTH: 600 nm-1050 nm
- CLEAR APERTURE: (S1) ∅5.20 mm, (S2) ∅4.63 mm
- NUMERICAL APERTURE: 0.2
- FOCAL LENGTH: 11 mm
- FOCAL LENGTH TOLERANCE: ±1.0 %
- BACK FOCAL LENGTH(REF): bf=9.6 mm
- DIAMETER TOLERANCE: ±0.015 mm
- THICKNESS TOLERANCE: ±0.05 mm
- CHAMFER: 0.2 mm, 45 °
- SURFACE QUALITY: 40-20 SCRATCH-DIG
- CENTRATION: <30 arcmin
- MAXIMUM TEMPERATURE: 250 °C(482 °F)
- AR COATING(S1,S2): Ravg<0.5 %@600-1050 nm

	PART DESCRIPTION	MATERIAL
①	LENS MOUNT	303 STAINLESS STEEL
②	AC90635-B	D-ZK3

DRAWING PROJECTION			LBTEK			
	NAME	DATE	MAC90635-B			
DRAWN	SHAN	APR./30th/24	ASPHERIC CONDENSER LENS			
APPROVAL	WCHENG	APR./30th/24	MATERIAL	WEIGHT	SCALE	REV
FOR INFORMATION ONLY NOT FOR MANUFACTURING PURPOSES			D-ZK3	1.19g	5:1	A