

	TYPE	SHAPE	CA	R	k	A4	A6	A8	A10	A12	A14	A16
S1	ASPHERE	CX	∅5.10	2.619752	-0.44952	-53267410E-4	-4.782383E-5	-3.558253E-6	1.813169E-7	0	0	0
S2	PLANO	PL	∅3.77	-12.675230	0	4.463095E-3	-8.996535E-5	-1.601088E-6	0	0	0	0

$$Z = \frac{Y^2}{R(1 + \sqrt{1 - (1 + K)Y^2 / R^2})} + \sum_i A_{2i} r^{2i}$$

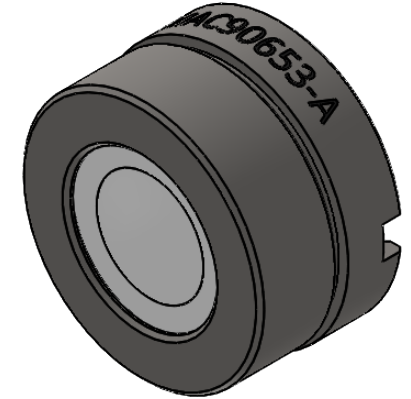
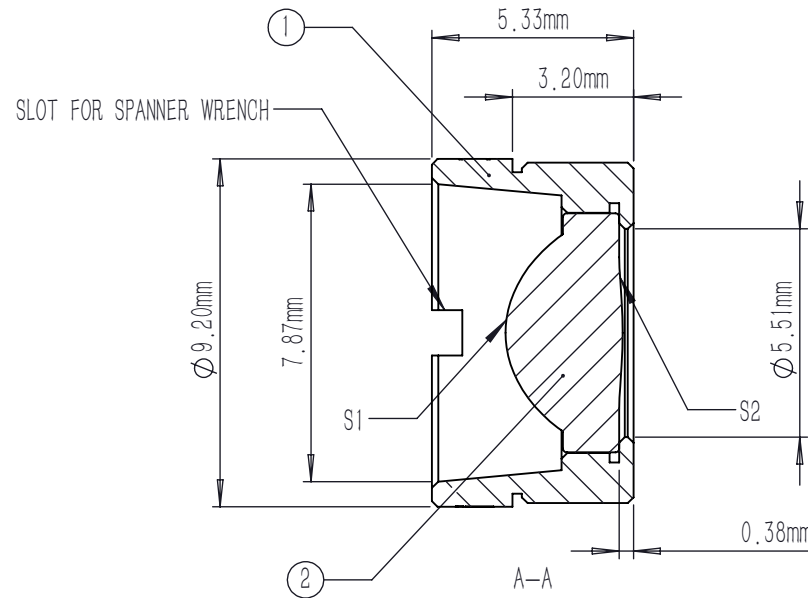
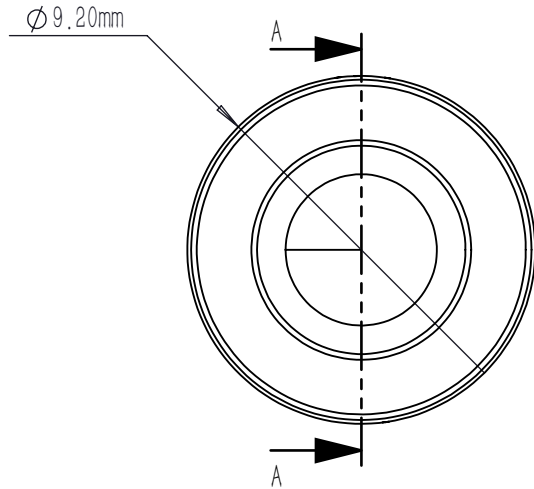

NOTES:

- MATERIAL: D-ZK3
- DESIGN WAVELENGTH: 685 nm
- WORKING WAVELENGTH: 350 nm-700 nm
- CLEAR APERTURE: (S1) ∅5.10 mm, (S2) ∅3.77 mm
- NUMERICAL APERTURE: 0.6
- FOCAL LENGTH: 4.0 mm
- FOCAL LENGTH TOLERANCE: ±1.0 %
- BACK FOCAL LENGTH(REF): bf=2.7 mm
- DIAMETER TOLERANCE: ±0.015 mm
- THICKNESS TOLERANCE: ±0.03 mm
- CHAMFER: 0.2 mm, 45 °
- SURFACE QUALITY: 40-20 SCRATCH-DIG
- CENTRATION: <30 arcmin
- MAXIMUM TEMPERATURE: 250 °C(482 °F)
- AR COATING(S1,S2): Ravg<0.5 %@350-700 nm

	PART DESCRIPTION	MATERIAL
①	LENS MOUNT	303 STAINLESS STEEL
②	AC90653-A	D-ZK3

DRAWING PROJECTION				LBTEK			
	NAME	DATE	MAC90653-A				
DRAWN	SHAN	APR./30th/24	ASPHERIC CONDENSER LENS				
APPROVAL	WCHENG	APR./30th/24	MATERIAL	WEIGHT	SCALE	REV	
FOR INFORMATION ONLY NOT FOR MANUFACTURING PURPOSES			D-ZK3	1.19g	5:1	A	