

	TYPE	SHAPE	CA	R	k	A4	A6	A8	A10	A12	A14	A16
S1	ASPHERE	CX	∅1.60	2.838589	-0.576643	0	0	0	0	0	0	0
S2	PLANO	PL	∅1.14	PLANO	0	0	0	0	0	0	0	0

$$Z = \frac{Y^2}{R(1 + \sqrt{1 - (1 + K)Y^2/R^2})} + \sum_i A_{2i} r^{2i}$$

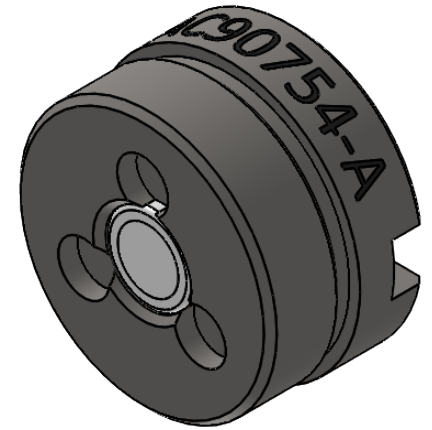
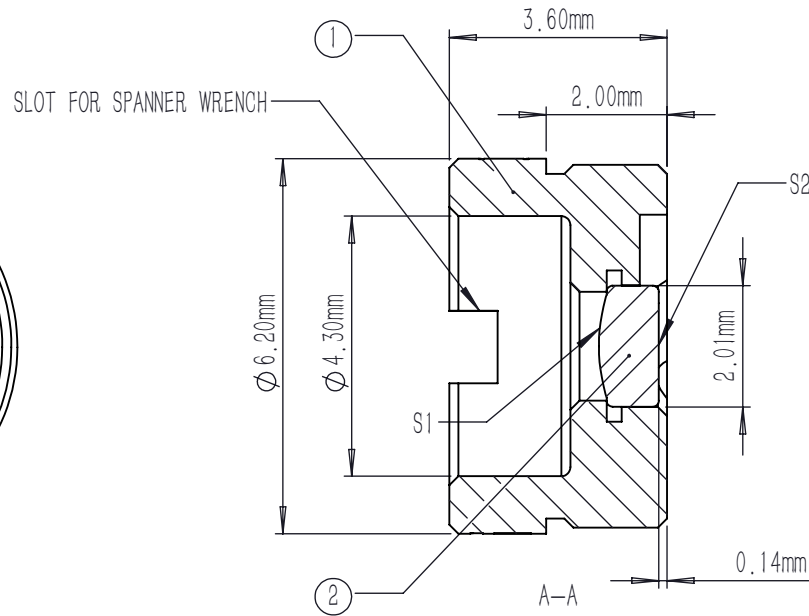
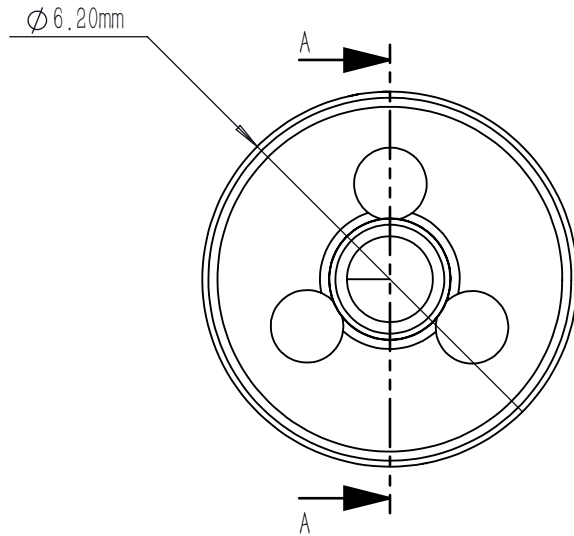

NOTES:

1. MATERIAL: D-ZK3
2. DESIGN WAVELENGTH: 1550 nm
3. WORKING WAVELENGTH: 350 nm-700 nm
4. CLEAR APERTURE: (S1) ∅1.60 mm, (S2) ∅1.14 mm
5. NUMERICAL APERTURE: 0.2
6. FOCAL LENGTH: 5.0 mm
7. FOCAL LENGTH TOLERANCE: ±1.0 %
8. BACK FOCAL LENGTH(REF): bf=4.4 mm
9. DIAMETER TOLERANCE: ±0.015 mm
10. THICKNESS TOLERANCE: ±0.05 mm
11. CHAMFER: 0.2 mm, 45 °
12. SURFACE QUALITY: 40-20 SCRATCH-DIG
13. CENTRATION: <30 arcmin
14. MAXIMUM TEMPERATURE: 250 °C(482 °F)
15. AR COATING(S1,S2): Ravg<0.5 %@350-700 nm

	PART DESCRIPTION	MATERIAL
①	LENS MOUNT	303 STAINLESS STEEL
②	AC90754-A	D-ZK3

DRAWING PROJECTION				<b>LBTEK</b>			
	NAME	DATE	MAC90754-A				
DRAWN	SHAN	APR./30th/24	ASPHERIC CONDENSER LENS				
APPROVAL	WCHENG	APR./30th/24	MATERIAL	WEIGHT	SCALE	REV	
FOR INFORMATION ONLY NOT FOR MANUFACTURING PURPOSES			D-ZK3	0.53g	8:1	A	