

	TYPE	SHAPE	CA	R	k	A4	A6	A8	A10	A12	A14	A16
S1	ASPHERE	CX	Ø5.50	10.667684	-0.686129	1.038298E-5	0	0	0	0	0	0
S2	PLANO	PL	Ø5.15	PLANO	0	0	0	0	0	0	0	0

$$Z = \frac{Y^2}{R(1 + \sqrt{1 - (1 + K)Y^2 / R^2})} + \sum_i A_{2i} r^{2i}$$

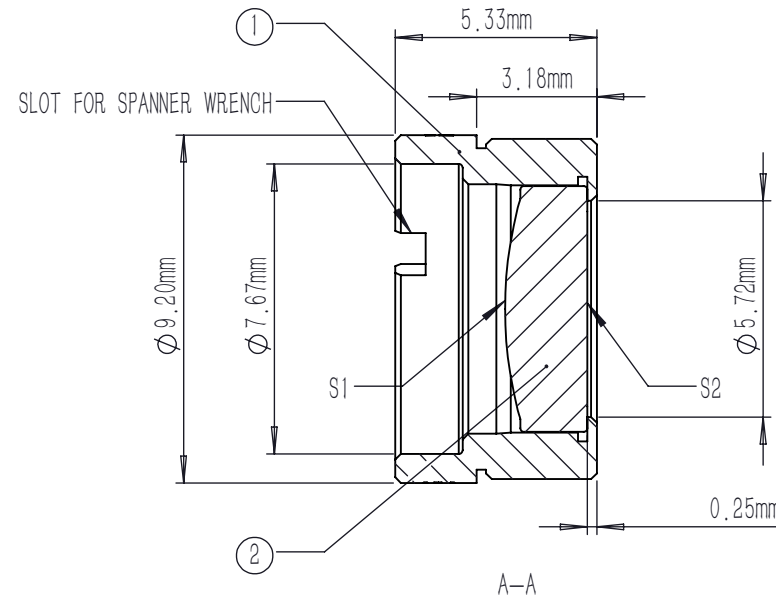
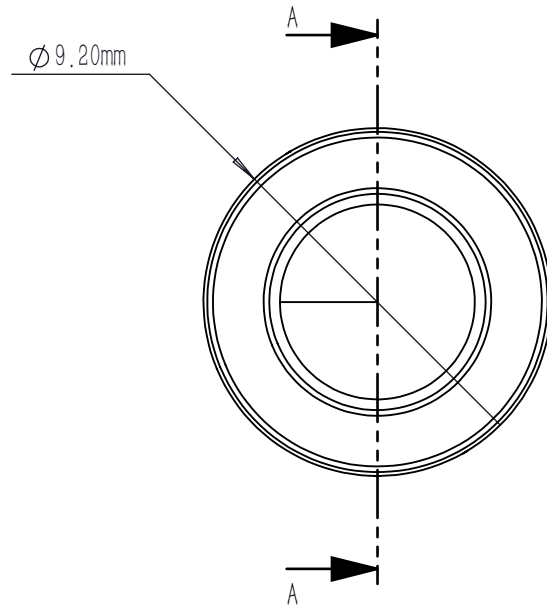

NOTES:

- MATERIAL: D-ZK3
- DESIGN WAVELENGTH: 780 nm
- WORKING WAVELENGTH: 1000 nm-1700 nm
- CLEAR APERTURE: (S1) Ø5.50 mm, (S2) Ø5.15 mm
- NUMERICAL APERTURE: 0.2
- FOCAL LENGTH: 18.4 mm
- FOCAL LENGTH TOLERANCE: ±1.0 %
- BACK FOCAL LENGTH(REF): bf=17.1 mm
- DIAMETER TOLERANCE: ±0.015 mm
- THICKNESS TOLERANCE: ±0.05 mm
- CHAMFER: 0.2 mm, 45 °
- SURFACE QUALITY: 40-20 SCRATCH-DIG
- CENTRATION: <30 arcmin
- MAXIMUM TEMPERATURE: 250 °C(482 °F)
- AR COATING(S1,S2): Ravg<0.5 %@1000-1700 nm

	PART DESCRIPTION	MATERIAL
①	LENS MOUNT	303 STAINLESS STEEL
②	AC91558-C	D-ZK3

DRAWING PROJECTION			LBTEK			
NAME	DATE	MAC91558-C				
DRAWN	SHAN	APR./30th/24	ASPHERIC CONDENSER LENS			
APPROVAL	WCHENG	APR./30th/24	MATERIAL	WEIGHT	SCALE	REV
FOR INFORMATION ONLY NOT FOR MANUFACTURING PURPOSES			D-ZK3	1.28g	5:1	A