

	PART DESCRIPTION	MATERIAL
①	LENS MOUNT	303 STAINLESS STEEL
②	AD101-A	N-BAK4
		SF5

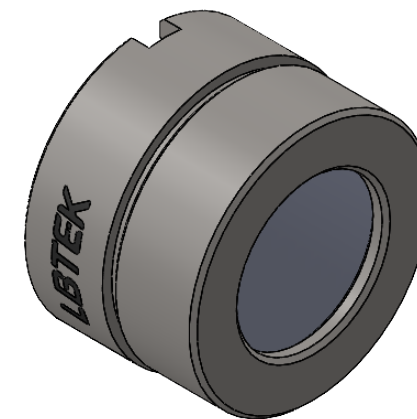
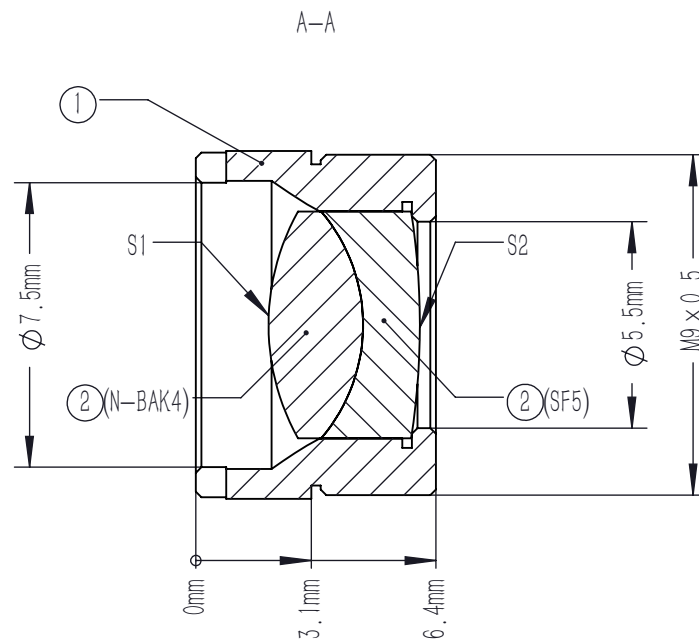
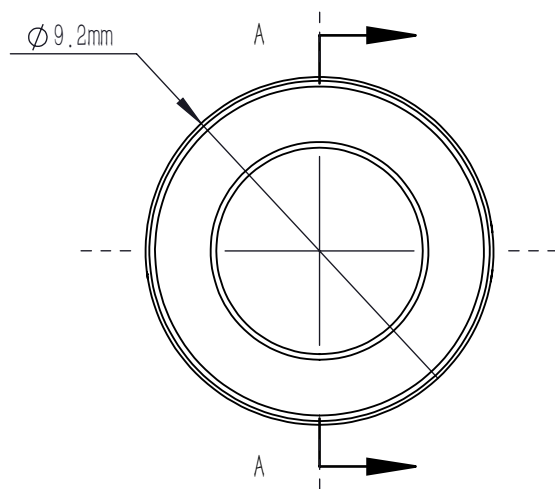

NOTES

- MATERIAL: N-BAK4/SF5
- DESIGN WAVELENGTH: 486.1 nm, 587.6 nm, 656.3 nm
- CLEAR APERTURE: $>90\%CA$
- OPERATION WAVELENGTH: 400 nm-700 nm
- DIAMETER TOLERANCE: $+0.0/-0.1\text{ mm}$
- THICKNESS TOLERANCE: $\pm 0.2\text{ mm}$
- FOCAL LENGTH: $10.0\text{ mm} \pm 1\% @ 587.6\text{ nm}$
- BACK FOCAL LENGTH(REF): 7.9 mm
- SURFACE QUALITY (S/D) (S1,S2) : 40/20
- SURFACE POWER (S1,S2) : $3\lambda/2 @ 632.8\text{ nm}$
- SURFACE IRREGULARITY(S1,S2): $\lambda/4 @ 632.8\text{ nm}$
- CENTRATION: $<3\text{ arcmin}$
- CHAMFER: $<0.2\text{ mm}, 45^\circ$
- AR COATING (S1,S2) : $R_{avg} < 0.5\% @ 400\text{ nm}-700\text{ nm}$ (6° AOI , single)

DRAWING PROJECTION			LBTEK			
		NAME	DATE	MAD101-A		
DRAWN	SHAN	MAY./7th/25	ACHROMATIC DOUBLETS			
APPROVAL	WCHENG	MAY./7th/25	MATERIAL	WEIGHT	SCALE	REV
FOR INFORMATION ONLY NOT FOR MANUFACTURING PURPOSES			N/A	1.58 g	5:1	A