

	PART DESCRIPTION	MATERIAL
①	LENS MOUNT	303 STAINLESS STEEL
②	AD205-B	N-LAK22
		N-SF6

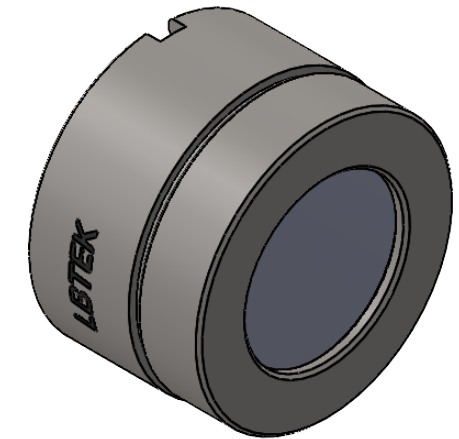
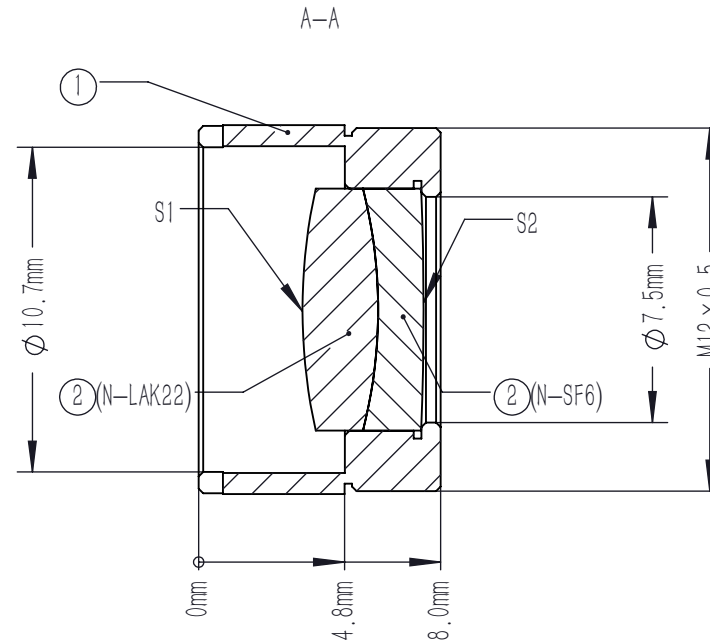
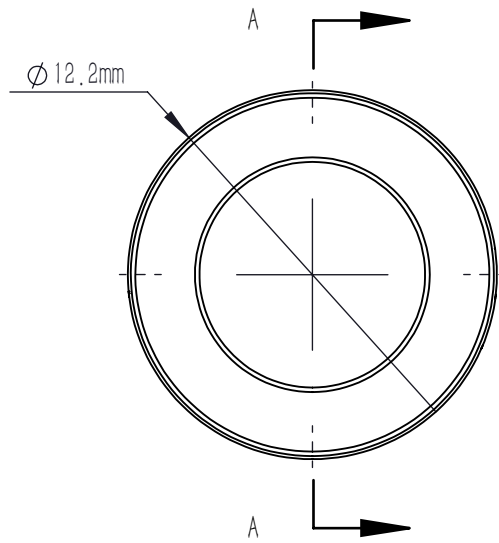

NOTES

1. MATERIAL: N-LAK22/N-SF6
2. DESIGN WAVELENGTH: 706.5 nm, 855 nm & 1015 nm
3. CLEAR APERTURE: >90%CA
4. OPERATION WAVELENGTH: 700 nm-1100 nm
5. DIAMETER TOLERANCE: +0.0/-0.1 mm
6. THICKNESS TOLERANCE: ±0.2 mm
7. FOCAL LENGTH: 30.0 mm ±1%@855 nm
8. BACK FOCAL LENGTH(REF): 27.7 mm
9. SURFACE QUALITY (S/D) (S1,S2) : 40/20
10. SURFACE POWER (S1,S2) : $3\lambda/2@632.8$ nm
11. SURFACE IRREGULARITY(S1,S2): $\lambda/4@632.8$ nm
12. CENTRATION: <3 arcmin
13. CHAMFER: <0.2 mm, 45°
14. AR COATING (S1,S2) : $R_{avg}<0.5\%@700$ nm-1100 nm (6° AOI, single)

DRAWING PROJECTION				LBTEK			
				MAD205-B			
	NAME		DATE	ACHROMATIC DOUBLETS			
DRAWN	SHAN		MAY./7th/25				
APPROVAL	WCHENG		MAY./7th/25	MATERIAL	WEIGHT	SCALE	REV
FOR INFORMATION ONLY NOT FOR MANUFACTURING PURPOSES				N/A	2.73 g	4:1	A