

剖面 A-A

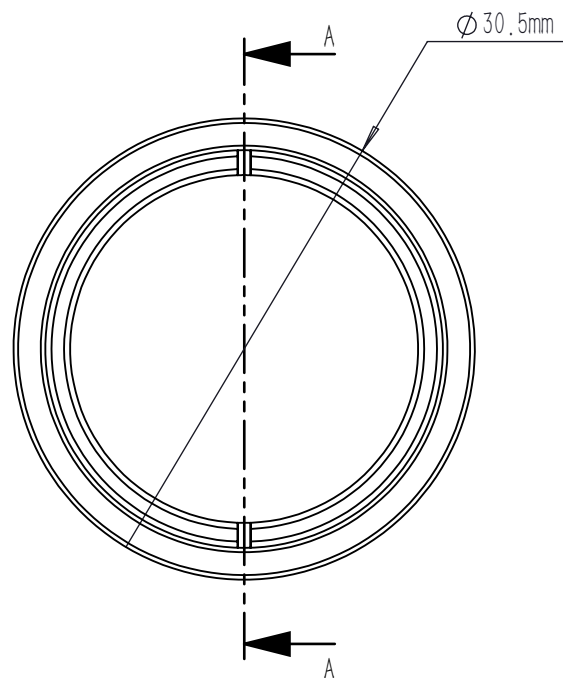

NOTES:

1. DESIGN WAVELENGTH: 488 nm, 707 nm&1064 nm
2. CLEAR APERTURE: >90 %CA
3. OPERATION WAVELENGTH: 400 nm-1100 nm
4. DIAMETER TOLERANCE: +0.0/-0.1 mm
5. THICKNESS TOLERANCE: ±0.1 mm
6. FOCAL LENGTH: 30.0 mm ± 1 % @ 707 nm
7. BACK FOCAL LENGTH: 21.2 mm
8. SURFACE QUALITY (S/D) (S1,S2) : 60/40
9. SURFACE POWER (S1,S2) :  $3\lambda/2$  @ 632.8 nm
10. SURFACE IRREGULARITY (S1,S2) :  $\lambda/4$  @ 632.8 nm
11. CENTRATION: <3 arcmin
12. CHAMFER: <0.2 mm, 45°
13. AR COATING (S1,S2) :  $R_{avg} < 1\%$  @ 400 nm-1100 nm, 0° AOI

	PART DESCRIPTION	MATERIAL
①	SM1-16.5A	ANODIZED ALUMINIUM
②	AD405-AB	BAFN11
		N-SF6
③	SM1R	ANODIZED ALUMINIUM

DRAWING PROJECTION				<b>LBTEK</b>			
	NAME	DATE	MAD405-AB				
DRAWN	SHAN	JUL./30th/24	ACHROMATIC DOUBLETS				
APPROVAL	WCHENG	JUL./30th/24	MATERIAL	WEIGHT	SCALE	REV	
FOR INFORMATION ONLY NOT FOR MANUFACTURING PURPOSES			N/A	31.82 g	2:1	A	