

LBTEK

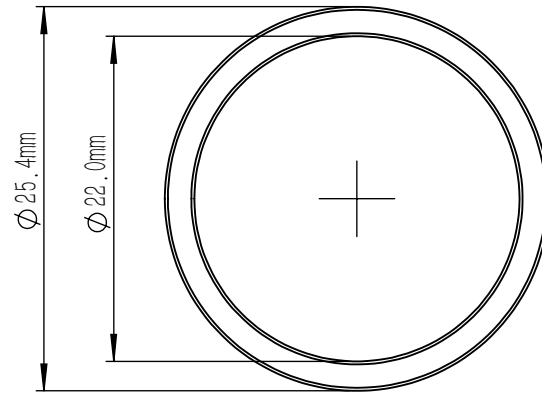

NOTES

1. MATERIAL: Schott Borofloat & Soda Lime
2. CWL: 600 nm ± 2 nm
3. FWHM: 10 nm ± 2 nm
4. TRANSMISSION: $>90\%$
5. STOP BAND: $>0D4@200-1100$ nm
6. BEST OPERATING TEMPERATURE: 23°C
7. SNAP RING PROCESSING: BLACK ANODIZED
8. OPERATING TEMPERATURE: $-50^{\circ}\text{C} \sim +80^{\circ}\text{C}$
9. SURFACE QUALITY(S/D): 80/50

DRAWING PROJECTION			LBTEK			
	NAME	DATE	MBF10-600-10			
DRAWN	LTAN	Nov./5th/25	BANDPASS FILTER CWL: 600 nm ± 2 nm, FWHM: 10 nm ± 2 nm			
APPROVAL	WCHENG	Nov./5th/25	MATERIAL	WEIGHT	SCALE	REV
FOR INFORMATION ONLY NOT FOR MANUFACTURING PURPOSES			Schott Borofloat & Soda Lime	7 g	2:1	C