

NUMBER	PART DESCRIPTION	MATERIAL
①	MECHANICAL HOUSING	BLACK ANODIZED ALUMINUM
②	BS1319-A	N-BK7

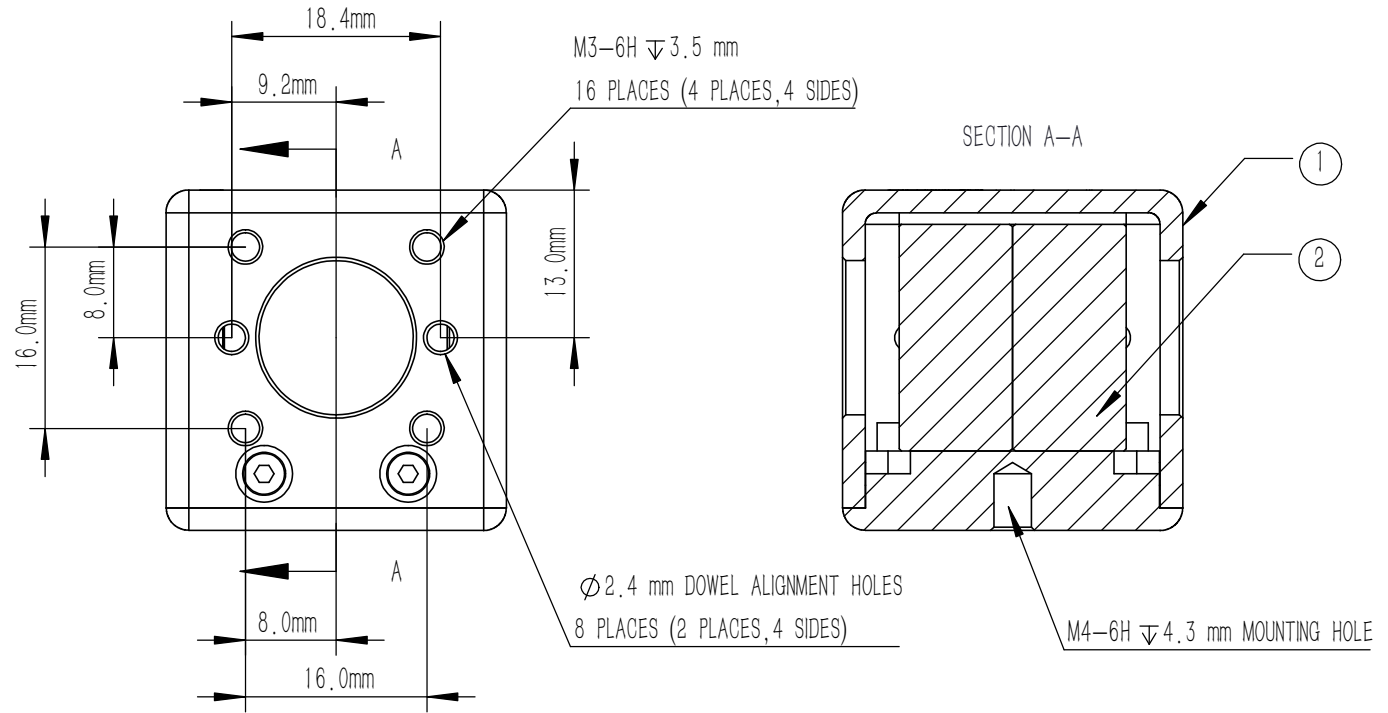

NOTES

BS1319-A:

- CLEAR APERTURE: >80%CA
- AR COATING (S1, S2, S3, S4) : $R_{avg} < 0.5\%$ @400 nm-700 nm (6° AOI, SINGLE SURFACE)
- ANGLE TOLERANCE: $\pm 5'$
- COATING (S5) : SPLITTING COATING
 $T_{abs} = (90 \pm 10)\%$, $R_{abs} = (10 \pm 5)\%$;
 $|T_s - T_p| < 10\%$, $|R_s - R_p| < 5\%$; $T_{abs} + R_{abs} > 90\%$
- GLUED (S5, S6) : NOA61
- SPLIT RATIO (R:T) : 10:90
- TRANSMITTED BEAM DEVIATION: $0^\circ \pm 5$ arcmin
- REFLECTED BEAM DEVIATION: $90^\circ \pm 5$ arcmin
- SURFACE QUALITY (S1, S2, S3, S4) : 40/20 (S/D)
- WAVEFRONT ERROR(RMS): $\lambda/4@633$ nm
- SURFACE FLATNESS (S1, S2, S3, S4) : $\lambda/4@633$ nm
- OTHER SURFACES: FINE GROUND
- CHAMFER: 0.2 mm, 45°

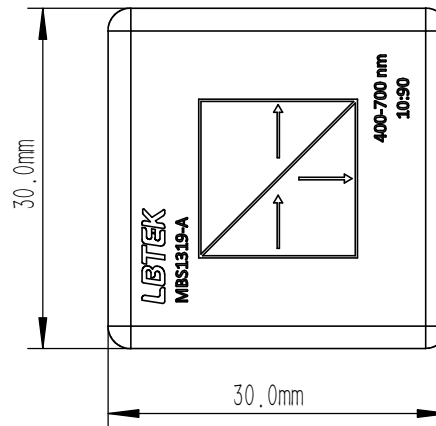

DRAWING PROJECTION		NAME		DATE		LBTEK			
						MBS1319-A			
DRAWN		LZHOU	MAR./12th/24		BEAM SPLITTER L=20.0 mm, R:T=10:90@400 nm-700 nm				
APPROVAL		WCHENG	MAR./12th/24		MATERIAL	WEIGHT	SCALE	REV	
FOR INFORMATION ONLY NOT FOR MANUFACTURING PURPOSES					6061-T6&N-BK7	49.1 g	3:2	A	