

NUMBER	PART DESCRIPTION	MATERIAL
①	MECHANICAL HOUSING	BLACK ANODIZED ALUMINUM
②	BS1337-A	N-BK7

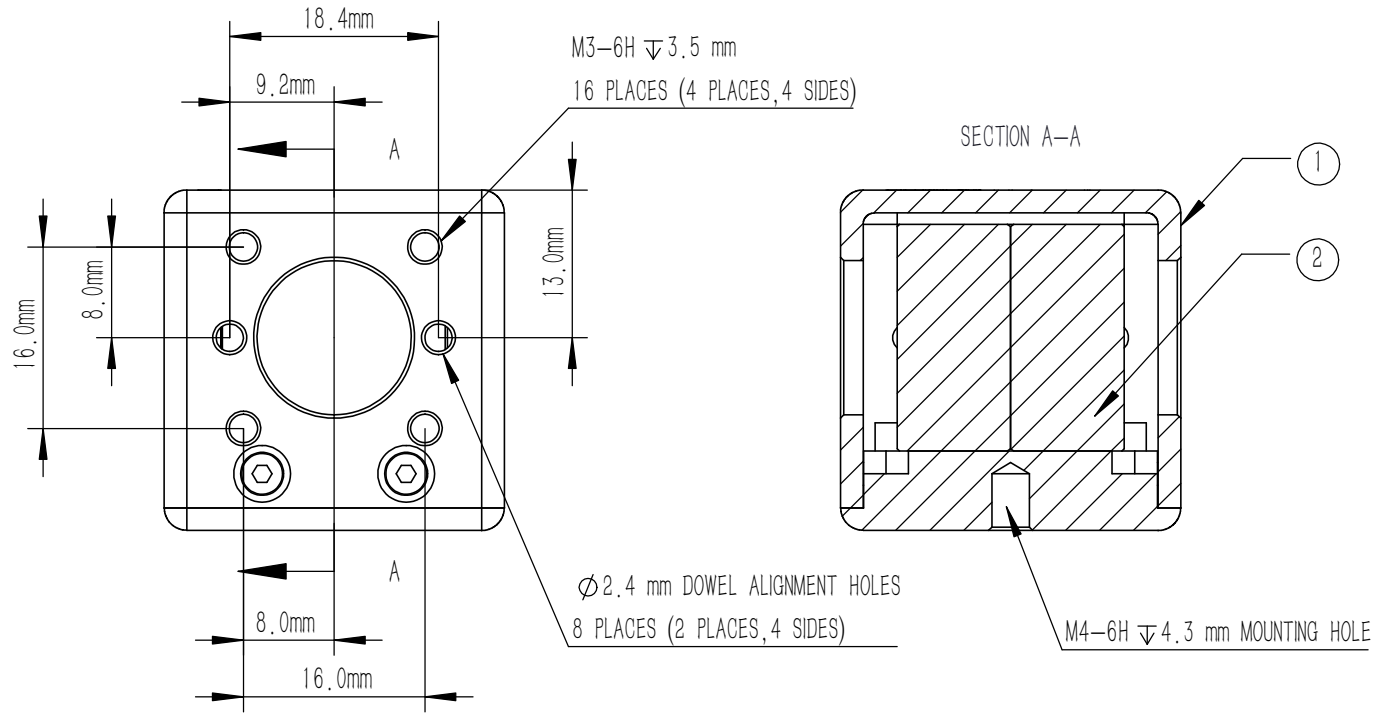

NOTES

BS1337-A:

- CLEAR APERTURE: >80%CA
- AR COATING (S1, S2, S3, S4) :  $R_{avg} < 0.5\%$  @400 nm-700 nm (6° AOI, SINGLE SURFACE)
- ANGLE TOLERANCE:  $\pm 5'$
- COATING (S5) : SPLITTING COATING  
 $T_{abs} = (62 \pm 10)\%$ ,  $R_{abs} = (27 \pm 10)\%$ ;  
 $|T_s - T_p| < 10\%$ ,  $|R_s - R_p| < 10\%$ ;  $T_{abs} + R_{abs} > 80\%$
- GLUED (S5, S6) : NOA61
- SPLIT RATIO (R:T) : 30:70
- TRANSMITTED BEAM DEVIATION:  $0^\circ \pm 5$  arcmin
- REFLECTED BEAM DEVIATION:  $90^\circ \pm 5$  arcmin
- SURFACE QUALITY (S1, S2, S3, S4) : 40/20 (S/D)
- WAVEFRONT ERROR(RMS):  $\lambda/4@633$  nm
- SURFACE FLATNESS (S1, S2, S3, S4) :  $\lambda/4@633$  nm
- OTHER SURFACES: FINE GROUND
- CHAMFER: 0.2 mm, 45°

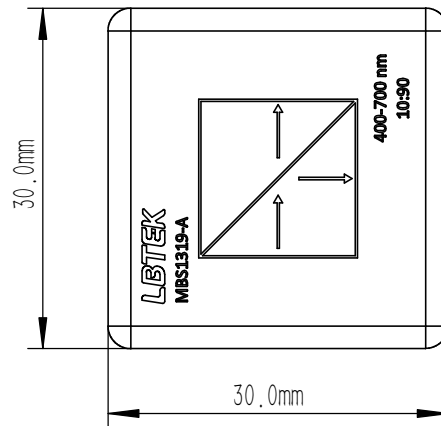

DRAWING PROJECTION		NAME		DATE		<b>LBTEK</b>			
						MBS1337-A			
						BEAM SPLITTER			
						L=20.0 mm, R:T=30:70@400 nm-700 nm			
APPROVAL	WCHENG	MAR./12th/24	MATERIAL	WEIGHT	SCALE	REV			
FOR INFORMATION ONLY NOT FOR MANUFACTURING PURPOSES		6061-T6&N-BK7		49.1 g	3:2	A			