

NUMBER	PART DESCRIPTION	MATERIAL
①	MECHANICAL HOUSING	BLACK ANODIZED ALUMINUM
②	BS1419-A	N-BK7

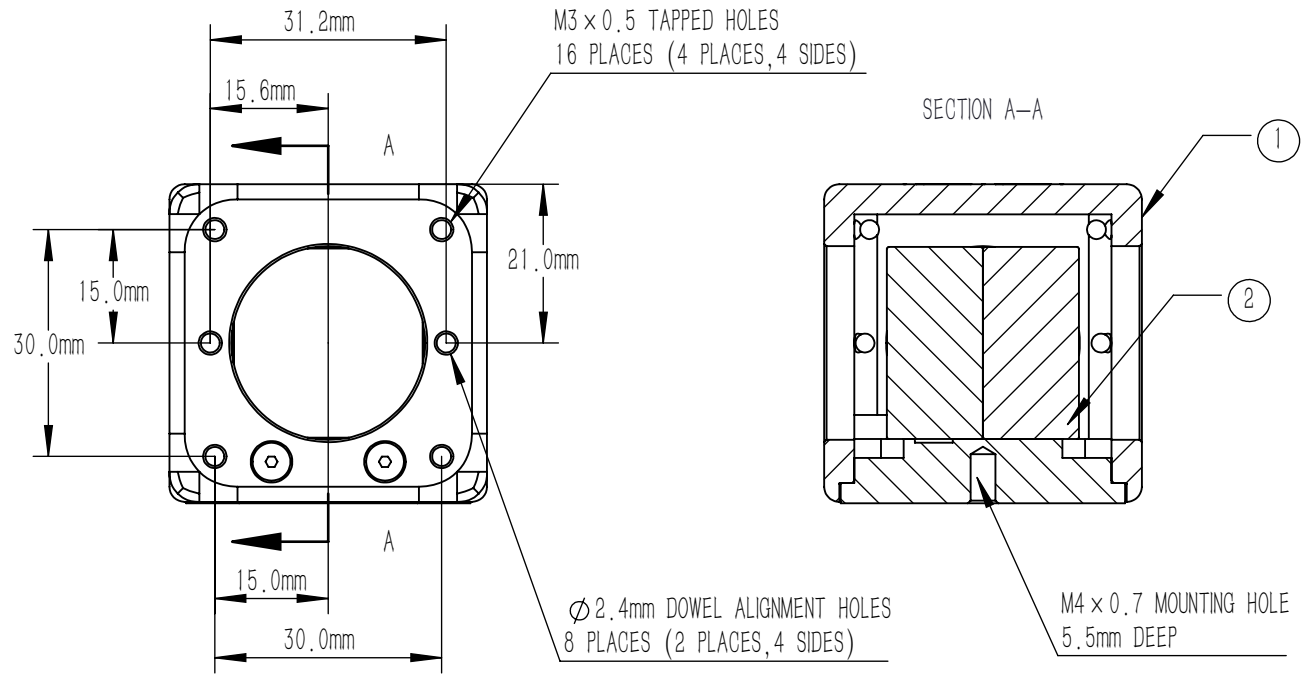
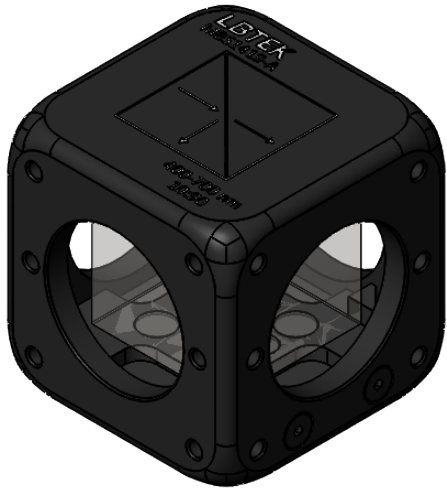

NOTES

BS1419-A:

- WORKING WAVELENGTH: 400 nm-700 nm
- CLEAR APERTURE: >80%CA
- AR COATING(S1,S2,S3,S4): $R_{avg} < 0.5\%$ @400 nm-700 nm (6° AOI, SINGLE SURFACE)
- ANGLE TOLERANCE: $\pm 5'$
- COATING(S5): SPLITTING COATING
 $T_{abs} = (90 \pm 10)\%$, $R_{abs} = (10 \pm 5)\%$;
 $|T_s - T_p| < 10\%$, $|R_s - R_p| < 5\%$; $T_{abs} + R_{abs} > 90\%$
- GLUED(S5,S6): NOA61
- SPLIT RATIO(R:T): 10:90
- TRANSMITTED BEAM DEVIATION: $0^\circ \pm 5$ arcmin
- REFLECTED BEAM DEVIATION: $90^\circ \pm 5$ arcmin
- SURFACE QUALITY(S1,S2,S3,S4): 40/20(S/D)
- WAVEFRONT ERROR(RMS): $\lambda/4$ @633 nm
- SURFACE FLATNESS(S1,S2,S3,S4): $\lambda/4$ @633 nm
- OTHER SURFACES: FINE GROUND
- CHAMFER: 0.2 mm, 45°

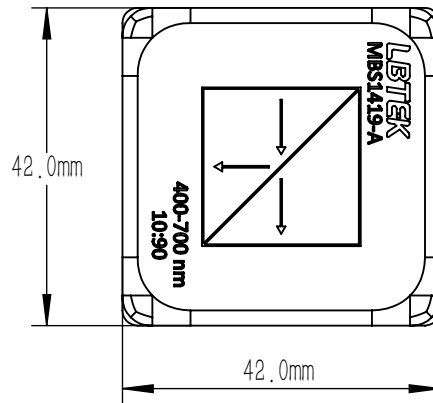

DRAWING PROJECTION							
	NAME	DATE	MBS1419-A				
DRAWN	LZHOU	AUG./12th/24	BEAM SPLITTER L=25.4 mm, R:T=10:90@400 nm-700 nm				
APPROVAL	WCHENG	AUG./12th/24	MATERIAL	WEIGHT	SCALE	REV	
FOR INFORMATION ONLY NOT FOR MANUFACTURING PURPOSES			N-BK7	129 g	1:1	C	