

NUMBER	PART DESCRIPTION	MATERIAL
①	MECHANICAL HOUSING	BLACK ANODIZED ALUMINUM
②	BS1491-A	N-BK7

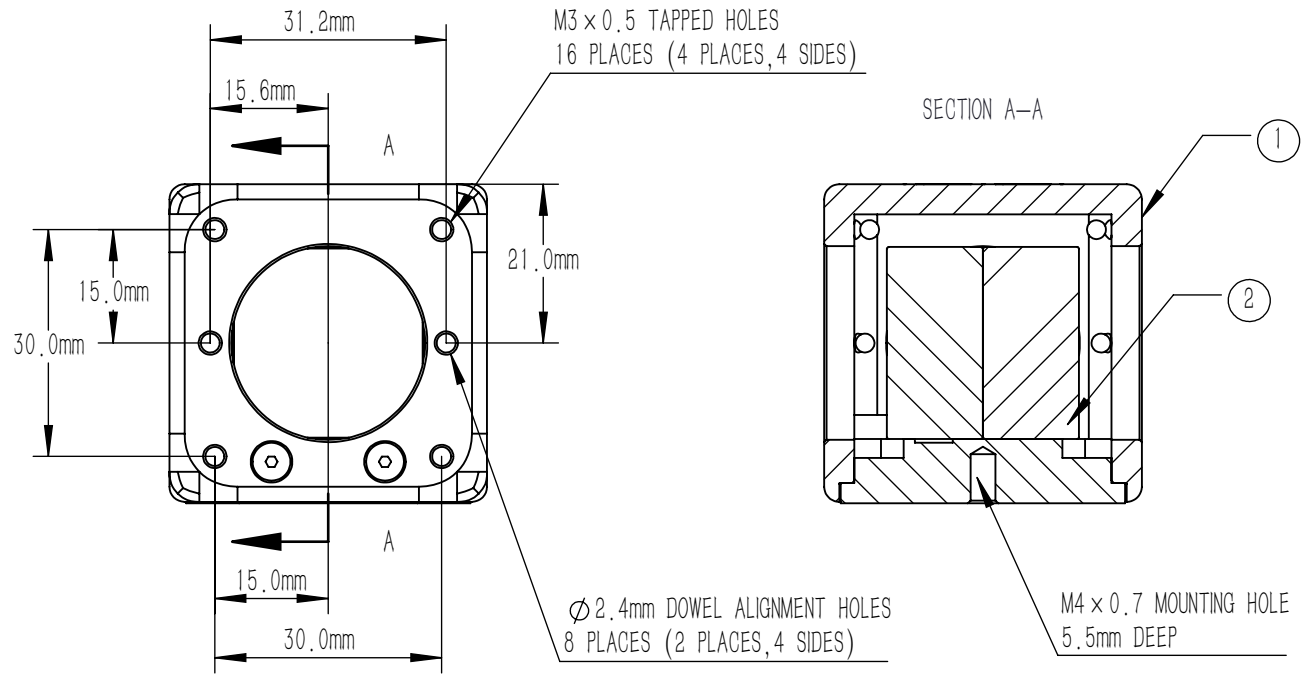

NOTES

- BS1491-A:
- CLEAR APERTURE: 80% CA
 - AR. COATING(S1,S2,S3,S4): $R_{avg} < 0.5\%$ @ 400 nm-700 nm (6° AOI, SINGLE SURFACE)
 - ANGLE TOLERANCE: $\pm 5'$
 - COATING(S5): SPLITTING COATING
 $T_{abs} = (7 + 10/-5)\%$, $R_{abs} = (87 \pm 10)\%$; $|T_s - T_p| < 10\%$
 $|R_s - R_p| < 10\%$; $T_{abs} + R_{abs} > 85\%$, AOI=0°
 - GLUED(S5,S6): NOA61
 - SPLIT RATIO(R:T): 90:10
 - TRANSMITTED BEAM DEVIATION: $0^\circ \pm 5$ arcmin
 - REFLECTED BEAM DEVIATION: $90^\circ \pm 5$ arcmin
 - SURFACE QUALITY(S1,S2,S3,S4): 40/20(S/D)
 - WAVEFRONT ERROR: $\lambda/4$ @ 633 nm
 - SURFACE FLATNESS(S1,S2,S3,S4): $\lambda/4$ @ 633 nm
 - OTHER SURFACES: FINE GROUND
 - CHAMFER: 0.2 mm, 45°

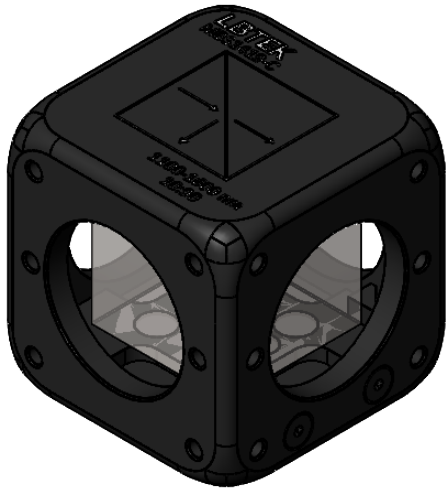
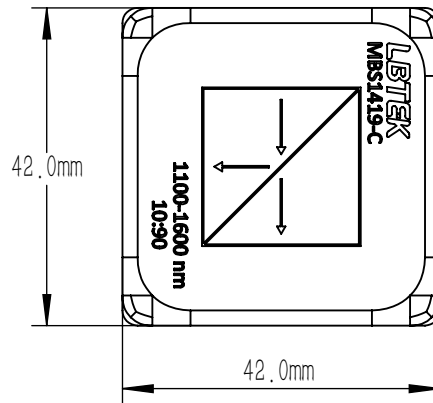

DRAWING PROJECTION			LBTEK			
NAME	DATE	MBS1491-A				
DRAWN	LTAN	Oct./10th/24	BEAM SPLITTER L=25.4 mm, R:T=90:10@400 nm-700 nm			
APPROVAL	WCHENG	Oct./10th/24	MATERIAL	WEIGHT	SCALE	REV
FOR INFORMATION ONLY NOT FOR MANUFACTURING PURPOSES			N-BK7	129 g	1:1	B