

	PART DESCRIPTION	MATERIAL
①	SM05-8A	ANODIZED ALUMINIUM
②	CC10305-A	N-BK7
③	SM05R	ANODIZED ALUMINIUM

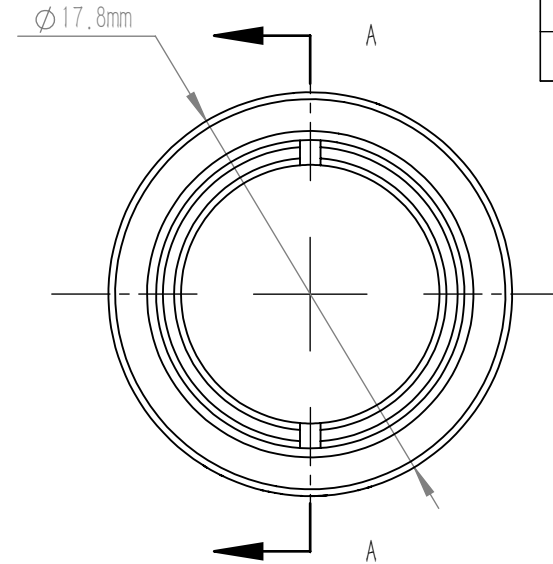
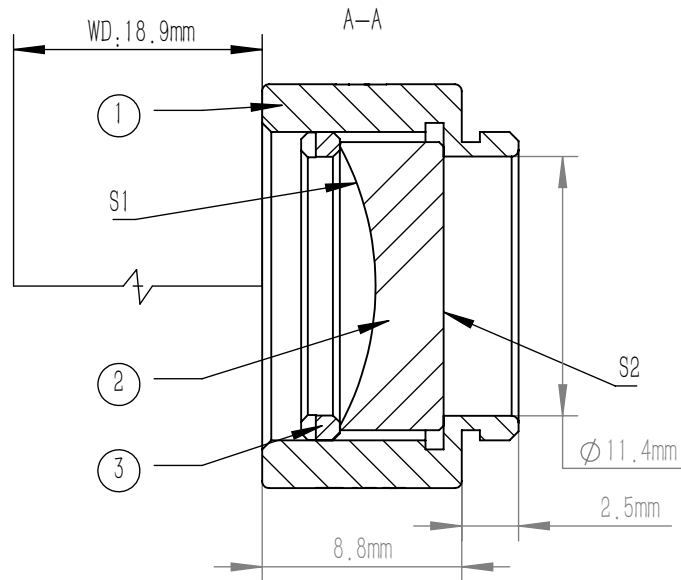

NOTES

1. DESIGN WAVELENGTH: 587.6 nm
2. OPERATION WAVELENGTH: 400 nm-700 nm
3. DIAMETER TOLERANCE: +0.0/-0.1 mm
4. THICKNESS TOLERANCE: ±0.1 mm
5. FOCAL LENGTH: -25.0 mm±1%
6. BACK FOCAL LENGTH(REF): -26.9 mm
7. CLEAR APERTURE: >90%CA
8. SURFACE QUALITY(S/D)(S1,S2): 40/20
9. SURFACE FLATNESS(S1):  $\lambda/2$  @ 632.8 nm
10. SURFACE POWER(S2):  $3\lambda/2$  @ 632.8 nm
11. SURFACE IRREGULARITY(S2):  $\lambda/4$  @ 632.8 nm
12. CENTRATION: <3 arcmin
13. CHAMFER: <0.2 mm, 45°
14. COATING(S1,S2): AR COATING Ravg <0.5% @ 400 nm-700 nm

DRAWING PROJECTION			<b>LBTEK</b>			
	NAME	DATE	MCC10305-A			
DRAWN	BSHU	Aug./19th/24	$\phi$ 12.7 mm, f=-25.0 mm PLANO CONCAVE LENS AR COATING 400-700 nm			
APPROVAL	WCHENG	Aug./19th/24	MATERIAL	WEIGHT	SCALE	REV
FOR INFORMATION ONLY NOT FOR MANUFACTURING PURPOSES			N-BK7	9.60 g	2:1	B