

	PART DESCRIPTION	MATERIAL
①	SM1-8A	ANODIZED ALUMINIUM
②	CC10613	N-BK7
③	SM1R	ANODIZED ALUMINIUM

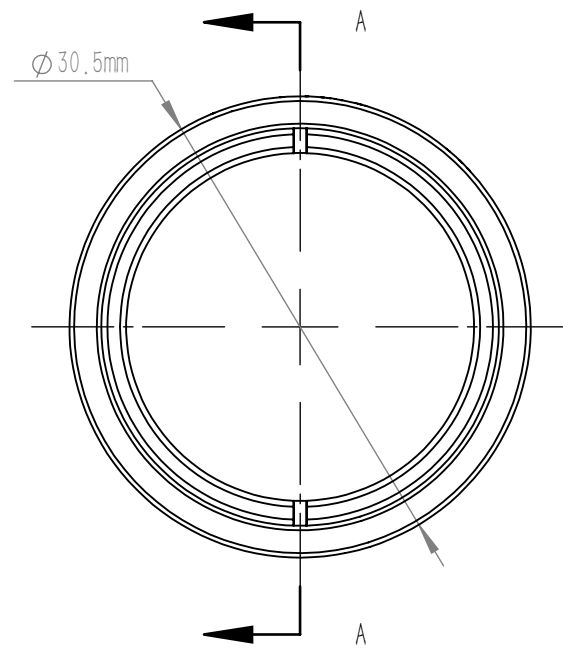
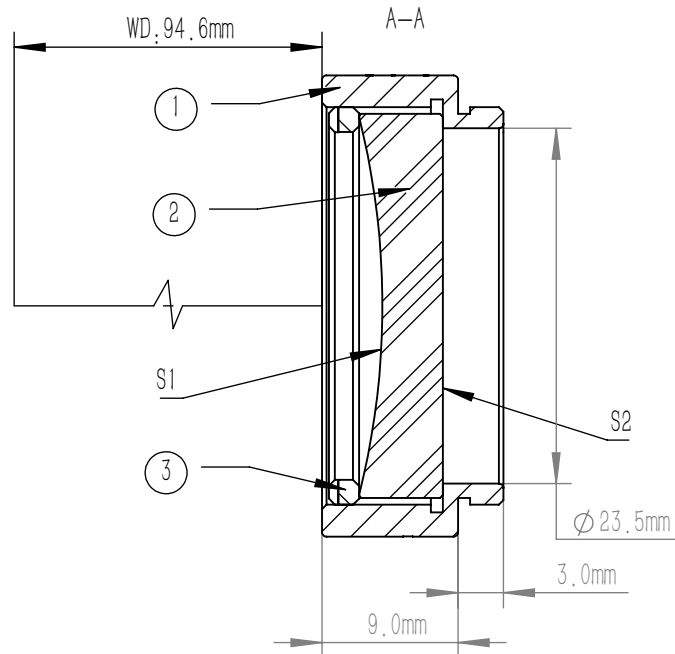

NOTES

1. DESIGN WAVELENGTH: 587.6 nm
2. OPERATION WAVELENGTH: 350 nm-2.0 μm
3. DIAMETER TOLERANCE: +0.0/-0.1 mm
4. THICKNESS TOLERANCE: ±0.1 mm
5. FOCAL LENGTH: -100.0 mm±1%
6. BACK FOCAL LENGTH(REF): -102.6 mm
7. CLEAR APERTURE: >90%CA
8. SURFACE QUALITY(S/D)(S1,S2): 40/20
9. SURFACE FLATNESS(S1): λ/2 @ 632.8 nm
10. SURFACE POWER(S2): 3λ/2 @ 632.8 nm
11. SURFACE IRREGULARITY(S2): λ/4 @ 632.8 nm
12. CENTRATION: <3 arcmin
13. CHAMFER: <0.2 mm, 45°
14. COATING(S1,S2): UNCOATED

DRAWING PROJECTION			LBTEK			
		NAME	DATE	MCC10613		
DRAWN	BSHU	Aug./19th/24	ϕ 25.4 mm, f=-100.0 mm PLANO CONCAVE LENS UNCOATED			
APPROVAL	WCHENG	Aug./19th/24	MATERIAL	WEIGHT	SCALE	REV
FOR INFORMATION ONLY NOT FOR MANUFACTURING PURPOSES			N-BK7	23.68g	2:1	B