

4 x SM1 (1.035in-40) SERIES INTERNAL THREAD
ACCEPTS ϕ 25.4mm [1.00in]

↑ A

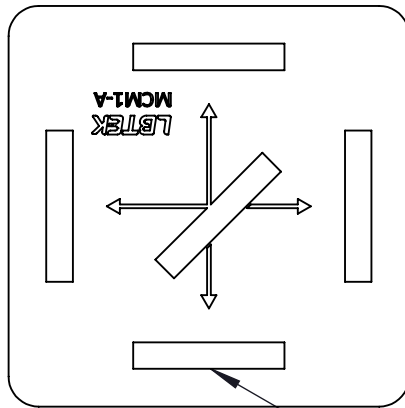
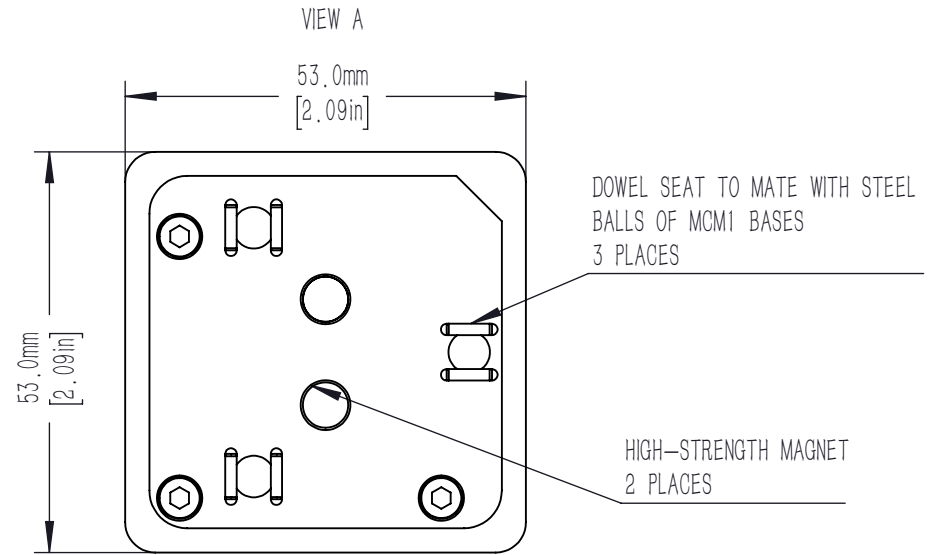

THIS EMISSION PORT IN THE REMOVABLE TOP IS
ALIGNED 3° OFF-AXIS
(0° OFF-AXIS ON OTHER THREE PORTS)

DRAWING PROJECTION			LBTEK			
	NAME	DATE				
DRAWN	CHZ	MAR./6th/20	30mm MAGNETIC QUICK DISMANTLING CUBE			
APPROVAL	ZXU	MAR./6th/20	MATERIAL	WEIGHT	SCALE	REV
FOR INFORMATION ONLY NOT FOR MANUFACTURING PURPOSES			N/A	0.170 Kg	1:1	C