

CENTER OF GRAVITY MOUNTED TO MKB-25 SHOULD BE LOCATED WITHIN MOUNTING REGION FOR MAXIMUM STABILITY

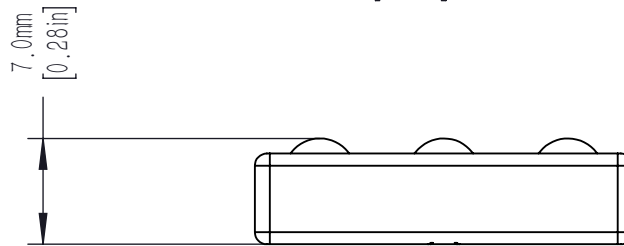

STEEL BALL TO MATE WITH V-GROOVE 3 PLACES

HIGH STRENGTH MAGNET 2 PLACES

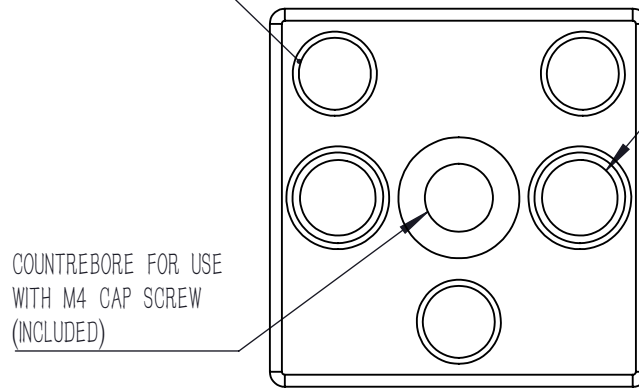

COUNTERBORE FOR USE WITH M4 CAP SCREW (INCLUDED)

DRAWING PROJECTION			LBTEK			
	NAME	DATE	MKB-25-A			
DRAWN	CZH	MAR./6th/20	MKB-25 TOP PLATE			
APPROVAL	ZXU	MAR./6th/20	MATERIAL	WEIGHT	SCALE	REV
FOR INFORMATION ONLY NOT FOR MANUFACTURING PURPOSES			N/A	0.011 Kg	2:1	B