

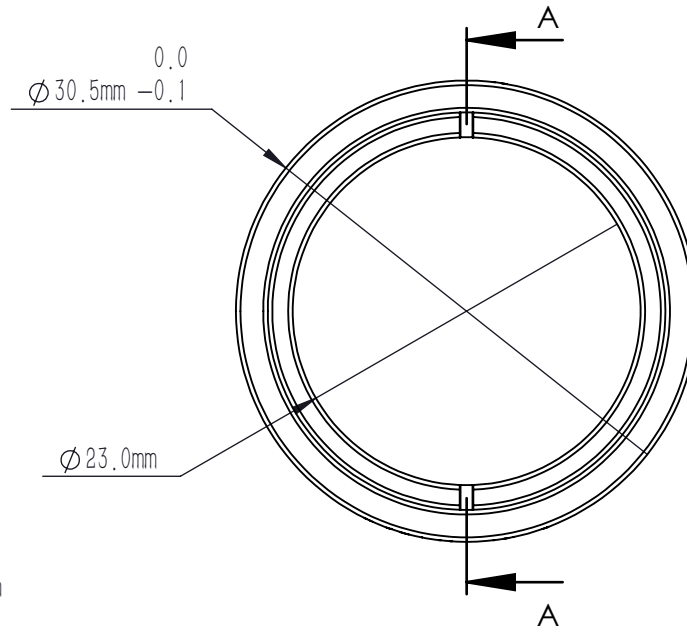

**MNDFA10-01-C**  
 $\Phi 25.4$  mm, OD=0.1  
 AR:1100-1700 nm

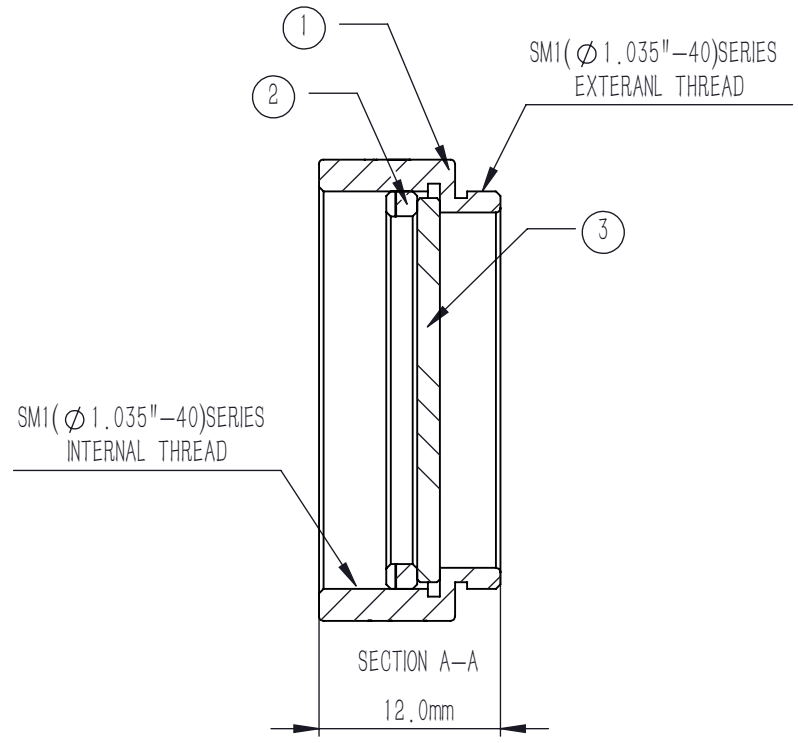

NUMBER	PART DESCRIPTION	MATERIAL
①	MECHANICAL HOUSING	BLACK ANODIZED ALUMINUM
②	SM1R	BLACK ANODIZED ALUMINUM
③	NDAFA10-01-C	ND Filter Glass



NOTES

1. OPERATION WAVELENGTH: 1100 nm-1700 nm
2. OPTICAL DENSITY:  $0.1 \pm 0.005 @ 1300$  nm
3. CLEAR APERTURE:  $>90\%$  CA
4. DIAMETER TOLERANCE:  $+0.00/-0.25$  mm
5. SURFACE QUALITY(S1,S2): 60/40(S/D)
6. SURFACE FLATNESS(S1,S2):  $\lambda/4 @ 632.8$  nm
7. PARALLELISM(S1,S2):  $<10$  arcsec
8. CHAMFER:  $<0.2$  mm,  $45^\circ$
9. COATING(S1): AR COATING,  $R_{avg} < 0.5\% @ 1100$  nm-1700 nm,  $6^\circ$  AOI
10. OTHER SURFACES: FINE GROUND

DRAWING PROJECTION			<b>LBTEK</b>			
	NAME	DATE	MNDFA10-01-C			
DRAWN	LZHOU	JUN./18th/24	ABSORPTIVE NEUTRAL DENSITY FILTER SM1 LENS TUBE, OD=0.1, AR: 1100 nm-1700 nm			
APPROVAL	WCHENG	JUN./18th/24	MATERIAL	WEIGHT	SCALE	REV
FOR INFORMATION ONLY NOT FOR MANUFACTURING PURPOSES			ND Filter Glass	8.5 g	2:1	B